

SPECTRUM

SPORTS INTL

MOBILE ZIPLINE

The Next Level of Mobile Adventure

OWNER/OPERATOR'S MANUAL

Gen III Models Manufactured After 11/01/2011



Attention!

IMPORTANT SAFETY INFORMATION INSIDE. READ THIS MANUAL BEFORE SETTING UP AND OPERATING THE MOBILE ZIP LINE (GEN III)

Mobile Zip Line™ (Gen III) Agreement

Product Name: _____

Model: _____ **Date Manufactured:** _____

Specialty Items: _____

Serial Number: _____

Passenger Capacity: _____

Company Name: _____

Customer Name: _____

Phone Number: _____

Address: _____

Certification: _____

I have read and understand the Receipt & Acknowledgement, Release of Liability, and Agreement & Acknowledgement contained in this manual.

Signature: _____

*Please mail or fax a copy of this agreement to:

324 W 2500 N Bldg A
North Logan, UT 84341
Fax: (435) 792-3884

TABLE OF CONTENTS

Mobile Zipline i

Owner/Operator’s Manual ii

Mobile Zip Line™ (Gen III) Agreement.....ii

Table of Contentsiii-v

List of Tables..... vi

List of Figures..... vi

1. Introduction 1

1.1 Receipt & Acknowledgment2

1.2 Manual Overview3

 1.2.1 Revisions 3

 1.2.2 Warning Signs..... 3

1.3 Accident Reporting4

1.4 Engineering Approval.....4

1.5 Certifications / Standards.....5

 1.5.1 ASTM Requirements for Owner/Operator Responsibilities..... 5

2. Product Operations..... 6

2.1 Rider Restrictions7

2.2 Ride Cycle.....7

2.3 Emergency Evacuation Plan.....9

3. Product Setup 10

3.1 Identify an Operating Area10

3.2 Remove the Zip Line from Vehicle11

3.3 Pin the Operator’s Safety Rail11

3.4 Connect the Steel Cables to the Tower12

3.5 Raise the Tower13

3.6 Stabilize the Tower13

3.7 Reposition the Hitch14

3.8 Lock the Tower Mast (Upright).....14

3.9 Connect and Tension the Guy Lines15

3.10 Prepare the Anchor Gear.....16

3.11 Measure the Anchor Distance16

3.12 Unroll and Inspect the Ride Cables17

3.13 Setup the Anchors17

 3.13.1 Setting Up 2 Anchor Vehicles 17

 3.13.2 Using a D.A.S.H. Device 19

 3.13.3 Using a Water Ballast Anchor 21

3.14 Setup the Inflatable Targets22

3.15 Inspect the Auto-Retract23

3.16 Prepare the Tower Gear25

3.17 Setup the Employee Safety Connection25

3.18 Setup the Trolley Inspection Connection.....26

3.19 Attach the Rider Lanyard.....27

3.20 Attach the Auto-Retract Brake Rope to the Trolley28

3.21 Prime the Auto-Retract28

3.22 Fence Off the Area30

4. Inspections and Maintenance..... 31

4.1 Time Based Inspections.....32

 4.1.1 Daily Inspections 32

 4.1.2 Quarterly Inspections..... 32

 4.1.3 Yearly Inspections 32

4.2 Inspection Checklists.....32

 4.2.1 Quick Reference Checklist..... 33

 4.2.2 Daily Inspection Checklist 34

 4.2.3 Quarterly Inspection Checklist 35

 4.2.4 Annual Inspection Checklist 36

4.3 Inspecting Wear Items37

4.4 Trailer Inspections37

 4.4.1 Trailer Inspection Checklist 38

4.5 Rope Inspection Guidelines40

4.6 Cable Inspections.....42

 4.6.1 Replacing the Cable..... 42

 4.6.2 Cable Replacement Options..... 43

 4.6.3 Wire Rope Inspection Comparison 44

4.7 Maintenance46

 4.7.1 Cleaning..... 46

 4.7.2 Product Storage (Winterization) 46

 4.7.3 Service Options 47

4.8 Non-Destructive Examination (NDE) Inspection Policy47

4.9 Mobile Zip Line Stickers48

 4.9.1 Auto-Retract® Stickers 50

5. Take Down 52

5.1 Dismantle Inflatable Targets52

5.2 Remove the Trolley and Lanyards.....52

5.3 Detach ATD Cables.....53

5.4 Dismantle Anchors.....53

 5.4.1 Dismantle 2 Vehicle Anchors 53

 5.4.2 Dismantle D.A.S.H. 53

 5.4.3 Dismantle Water Ballast Anchor(s) 54

5.5 Store the Cables.....54

5.6 Disconnect Guy Lines54

5.7 Unlock the Tower Mast.....54

5.8 Prep the Trailer for Lowering.....55

5.9 Lower the Tower56

5.10 Collect Tower Gear56

5.11 Prepare for Transit.....	56
6. Transportation.....	57
6.1 Transportation Dimensions.....	57
6.2 Connect to Tow Vehicle.....	57
6.3 Pre-Trip Inspection.....	58
6.4 Transportation Rules.....	59
7. Warranty.....	60
7.1 Warranties and Liabilities.....	60
7.2 Conclusion.....	64
Appendices.....	65
Appendix A. Forms.....	66
Appendix B. ASTM F 1305.....	67
Appendix C. Wiring Schematic.....	69
Appendix D. Wiring Diagrams.....	70
Appendix E. Wheel Lock Information.....	72

LIST OF TABLES

Table 1. Warning Signs.....	3
Table 2. Quick Reference Checklist.....	33
Table 3. Daily Inspection Checklist.....	34
Table 4. Quarterly Inspection Checklist.....	35
Table 5. Annual Inspection Checklist.....	36
Table 6. Mobile Zip Line Trailer Inspection Checklist.....	38
Table 7. Wire Rope Inspection Comparison.....	44
Table 8. Allowable broken strands by ASME Code.....	45

LIST OF FIGURES

Figure 1. Zip Line Operators.....	6
Figure 2. Warning and Rules Sign.....	7
Figure 3. Find a Safe Area.....	10
Figure 4. Remove Zip Line from Vehicle.....	11
Figure 5. Pin the Operator's Safety Rail.....	12
Figure 6. Loop Cable Around Mast.....	12
Figure 7. Secure the Ride Cable with Pin.....	12
Figure 8. Use the Pendant to Raise the Tower.....	13
Figure 9. Adjust the Jacks.....	14
Figure 10. Using Wheel Chocks.....	14
Figure 11. Yellow Mast Locks.....	15
Figure 12. Pin the Turnbuckle to the Trailer.....	15
Figure 13. 6" Deflection.....	16
Figure 14. Measure the Anchor Distance 1.....	16
Figure 15. Unroll the Ride Cables.....	17
Figure 16. 2 Anchor Vehicles.....	17
Figure 17. Install an ATD.....	18
Figure 18. Attaching a Cable to the ATD.....	18
Figure 19. Pin the Cable to the ATD.....	18
Figure 20. Connected ATD Cable.....	19
Figure 21. D.A.S.H. Anchor.....	20
Figure 22. Yellow Chock Bar.....	20

Figure 23. ATD Pivot Arm21

Figure 24. Connect Loose Chain Ends.....21

Figure 25. Water Ballast Anchor.....22

Figure 26. Inflatable Targets.....23

Figure 27. Remove the Auto-Retract Straps.....23

Figure 28. Check the Auto-Retract Pressure.....24

Figure 29. Auto-Retract Bubble Sight Eye.....24

Figure 30. Tower Gear.....25

Figure 31. Employee Harness.....26

Figure 32. Connect the Employee/Operator Lanyard.....26

Figure 33. Attach the Lanyard to the Trolley.....27

Figure 34. Attach the Backup Loop.....27

Figure 35. Attach the Auto-Retract Brake Rope28

Figure 36. Tower Employee – Auto-Retract Priming28

Figure 37. Ground Employee – Auto-Retract Priming29

Figure 38. Fencing off the Area (Ex. A).....30

Figure 39. Fencing off the Area (Ex. B).....30

Figure 40. Rope Inspection Warnings.....41

Figure 41. Rope Inspection Guidelines.....41

Figure 42. Single Wire Inspection Criteria for Wire Ropes.....42

Figure 43. Mobile Zip Line Stickers.....49

Figure 44. Auto-Retract Stickers.....51

Figure 45. Unlock Yellow Tower Locks55

Figure 46. Remove the Tire Chocks55

Figure 47. Tower is Ready to Lower.....56

Figure 48. Transportation Dimensions57

Figure 49. Improper Tow Connection58

Figure 50. Proper Tow Connection.....58

Figure 51. Mobile Zip Line (Gen III)/Zip Accessories & Parts Order Form.....66

Figure 52. Wiring Schematic.....69

Figure 53. Wiring Diagram 170

Figure 54. Wiring Diagram 271

Figure 55. Wheel Lock Information72

1. INTRODUCTION

Thank you for purchasing a quality-built climbing product from Spectrum Sports Intl. We take pride in our products and believe that we build the best products in our industry. Our philosophy is centered on a commitment of excellence in meeting the needs of our customers and providing quality products that are safe, exciting, and profitable. We encourage you to likewise develop a similar standard of quality and service.

What makes our team successful is:

- ✓ Commitment to a proper, effective, and profitable design.
- ✓ Third-Party Engineering on all our products.
- ✓ Manufacturing our products according to the “ASTM F-24” amusement industry safety standards.
- ✓ Testing designs before they are put into use and sold.
- ✓ Maximum customer through-put, generating high profits.
- ✓ Building quality products, which means the ownership costs are lower.
- ✓ Experience and leadership in the industry.
- ✓ In-house assembly on all of our products (this provides for exceptional Quality Control).

Your part in building a successful business using Spectrum Sports Intl products is to:

- Have a commitment to safe operation.
- Have consistent inspections for needed maintenance.
- Effectively and actively market and promote the product.
- Use Spectrum Sports Intl certified replacement parts.



Attention!

Always remember to follow all safety guidelines and use caution while operating your product.

Spectrum Sports Intl is a company that has designed the following products: Climb-N-Dangle®, Drop-A-Rock®, Grip-A-Rock®, RidgeLine®, Climb-N-Challenge®, Klime Wallz®, and Coconut Tree Climb®. This manual will be used to document the operating procedures and safety warnings associated with the Mobile Zip Line (Gen III)[™] product.



Attention!

The guidelines in this manual must be read and understood by all people operating the Mobile Zip Line (Gen III).

Copyright© Spectrum Sports Intl

Reproduction or translation of any part of this work beyond that permitted by Section 107 or 108 of the 1976 United States Copyright Act without permission of the copyright owner is unlawful. Requests for permission or further information should be addressed to Spectrum Sports Intl.

1.1 Receipt & Acknowledgment

This owner/operator's manual is an important document intended to help you become acquainted with the Mobile Zip Line (Gen III) product.



Attention!

Please read the following statement and contact Spectrum Sports Intl, in writing, if the intent of this document is unclear or questions arise. YOU SHOULD NOT OPERATE THE PRODUCTS MENTIONED IN THIS MANUAL IF YOU DO NOT FULLY UNDERSTAND HOW TO OPERATE THEM SAFELY!

“As owner/operator, I have received and read my copy of the Spectrum Sports Intl Mobile Zip Line (Gen III) product Operations Manual. I understand that the information outlined in this manual is subject to change at the sole discretion of Spectrum Sports Intl at any time. It is further understood that as an owner/operator of the Mobile Zip Line (Gen III) product, I have the responsibility to ensure that the correct and latest version of the manual is being used.

As an owner of the Mobile Zip Line (Gen III) product or authorized representative, it is my responsibility to keep this manual current with any changes that are made by Spectrum Sports Intl. In addition, if there is anything about the product and/or this manual that is unclear or not understood, it is my responsibility to seek clarification and not use the product until the issue is understood.”

Unless informed in writing, Spectrum Sports Intl assumes that the customer understands the Mobile Zip Line (Gen III) product and that there are no questions regarding the product, the contents of this document, and/or use of the product or how to operate this product.



Attention!

It is the sole responsibility of the customer to clarify any question or concern with Spectrum Sports Intl before use and/or operation.

1.2 Manual Overview

This manual is an introduction to the Mobile Zip Line (Gen III) product and its operation. The purpose of this manual is to provide a compilation of information that will assist you in proper and safe operation. This manual is designed to aid in educating you and your associates.

The purpose of this manual is to provide the product owner with the necessary information to transport, setup, inspect, operate, take-down, and maintain the Mobile Zip Line™ as effectively and safely as possible. This manual is in no way a total representation of all facts. Safe operation of this product is the sole responsibility of the owner/operator. Sound and reasonable judgment must be used at all times.

1.2.1 Revisions

Spectrum Sports Intl may make periodic additions, deletions, and modifications to this manual. These updates will, in the judgment of Spectrum Sports Intl, add to the quality of services offered. This manual must be kept up to date and should reflect all updates currently in use.





Attention!

Please check the following website for updates and/or safety issues regarding your Mobile Zip Line (Gen III): www.spectrumsports.com.

1.2.2 Warning Signs

The following warning signs will appear throughout this manual:

Table 1. Warning Signs

SYMBOL	WARNING NAME	DESCRIPTION
	Attention	This icon and font will be used to draw attention to important tips or setup procedures.
	Warning	This icon, and font, will be used to draw attention to important safety warnings.



Attention!

Spectrum Sports Intl will not warranty or stand behind any Mobile Zip Line (Gen III) that we have manufactured that does not use genuine and/or authorized replacement parts and/or cables. Any work and/or services that are performed on any Spectrum Sports Intl Mobile Zip Line (Gen III) that are not performed by an authorized Spectrum Sports Intl employee, voids any and all claims to any manufacturer's liability.

Read and understand this manual before installing and/or operating the product.



Warning!

Failing to comply with the information in this manual may result in serious injury or death. Use of the Spectrum Sports Intl Mobile Zip Line™ or its components for any purposes other than that intended by the manufacturer is not permitted. Owners and Operators are responsible for the safety and supervision of any person using the Spectrum Sports Intl Mobile Zip Line™ and are required to assure that proper installation and operation procedures are followed at all times.

1.3 Accident Reporting

Spectrum Sports Intl requires that any and all accidents are reported within 48hrs from the time of the accident.

We need the following information:

- Name of the injured.
- Place of the accident.
- An incident report.
- The route the accident occurred on.
- A description of the accident.
- A description of the proposed product failure.
- The employee's name.
- Copy of the inspection report/checklists.
- Date the employee was trained on the use of the product.

More information may be required at a later time. email a report to sales@spectrumsports.com or fax a report to 435-792-3884.

1.4 Engineering Approval

Our products have been designed and reviewed by third-party engineers that stand behind the product design. If it is necessary that you receive a copy of the engineering analysis, Spectrum Sports Intl will provide a copy contingent upon the signing of a "non-disclosure/non-compete agreement" and a small fee.

Please call Spectrum Sports Intl for details.



Attention!

The customer is responsible for finding what current codes are required to operate each Spectrum Sports Intl product within their state.



Attention!

Be sure that you are completely familiar with the safety and operation guidelines before you use the Mobile Zip Line (Gen III) product.

1.5 Certifications / Standards

Spectrum Sports Intl has the following certifications and meets/exceeds the following industry standards:



1.5.1 ASTM Requirements for Owner/Operator Responsibilities

“Owner/operators of amusement rides or devices shall have an inspection program consistent with the inspections outlined in Practice F 853 & Practice F 770. Inspection documents deemed appropriate by the owner/operator to be maintained in the ride file shall be filed in accordance with the procedures outlined in Practice F 770 and Practice F 853. The owner/operator of an amusement ride or device shall promptly notify the manufacturer of an incident, failure, or malfunction which, in his judgment, seriously affects the continued proper operation of the ride or device and is information of which the manufacturer should be aware.”

(Ref: ASTM International Standards on Amusement Rides and Devices: 7th Edition, Sections: 5.2.1-5.2.3)

2. PRODUCT OPERATIONS

This section of the manual will outline the operational procedures and duties associated with the Mobile Zip Line (Gen III) product. For safe and efficient operations Spectrum Sports Intl recommends 3 operators: Zip Assistant (Harnessing), Zip Master, and Zip Assistant (Unloading).

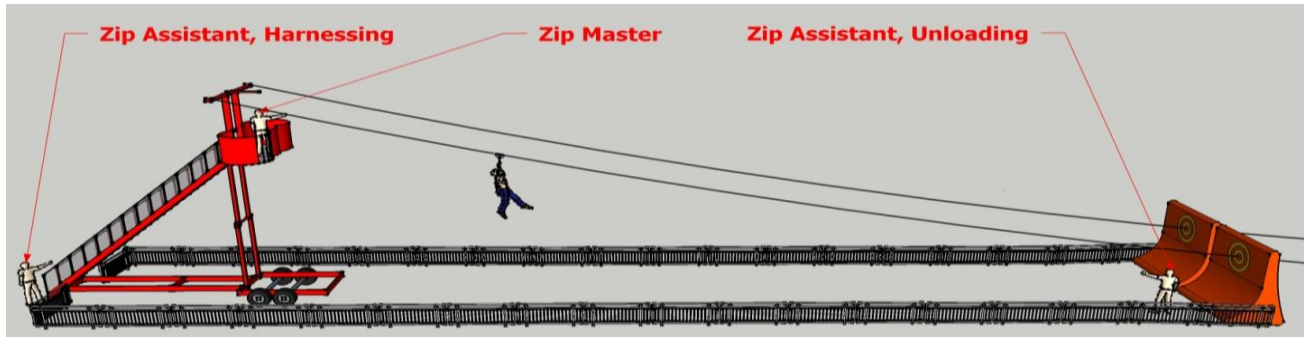

Figure 1. Zip Line Operators

Harnessing Zip Assistant

The role of the Harnessing Zip Assistant includes:

- Keeping the queue line and harness area in order.
- Collecting any tokens, tickets, or money for the Mobile Zip Line™ ride.
- Verbally explaining to the rider the Warning and Rules Sign and what to expect from the ride
- Harnessing the riders.
- Admitting the riders thru the gate onto the stairway.

Zip Master

The role of the Zip Master includes:

- Knowing and understanding how to safely **transport** the Mobile Zip Line™.
- Knowing and understanding how to **setup** the Mobile Zip Line™.
- Knowing and understanding how to **inspect** the Auto-Retract® Safety System and Mobile Zip Line™.
- Knowing and understanding how to **take-down** the Mobile Zip Line™.
- Reconfirming that each rider is properly harnessed and aware of warnings and rules on the Warning and Rules sign.
- Connecting riders to the zip line and giving final instructions before take-off.
- Controlling the flow of riders from the zip line tower.
- Monitoring the Auto-Retract® Safety System to verify that it is properly retracting the trolley.

Unloading Zip Assistant

The role of the Unloading Zip Assistant includes:

- Disconnecting the rider from the trolley lanyard once they arrive at the bottom of the ride.
 - Directing the rider safely out of the Landing Zone.
 - Keeping the Landing Zone free and clear of any objects or people.
- Ultimately it is the operators' responsibility to ensure that each Mobile Zip Line™ rider has a safe and enjoyable experience.**

2.1 Rider Restrictions

The following rider restrictions apply to the Mobile Zip Line (Gen III) product:

- Rider weight must be between 40 lbs. – 250 lbs. (18kg – 113kg).
- 2 riders at a time is permissible if the combined weight is 250 lbs. (113kg) or less.
- Rider heights must be between 40” – 6’8” (91cm – 203cm).
- Minimum age for riders is 6 years old.
- Long hair must be secured.
- Riders cannot be under the influence of any substance.
- Riders must be able to follow all verbal instructions from the operators.
- Riders are prohibited if they have health problems such as head, neck, back, or limb injuries; a heart condition; or are pregnant.
- Riders must have sufficient limbs to wear a full-body harness.

2.2 Ride Cycle

The standard Mobile Zip Line (Gen III) ride cycle will consist of the following:

1. Rider enters the queue line.
2. Any tokens, tickets, or money are collected, if applicable.
3. Zip Assistant verbally explains to the rider the items on the Warning and Rules sign.



Figure 2. Warning and Rules Sign

4. Rider confirms that they understand the items on the Warning and Rules sign.
5. Zip Assistant explains what is to be expected during the zip line experience.
6. The rider is harnessed. Sizes are as follows:
 - a. Small: 3' to 4' (91 to 120cm)

- b. M/L: 4' to 6' (120 to 180cm)
 - c. XL: 5'8" to 6'8" (170 to 203cm)
7. Zip Assistant allows the current rider onto the stairway when the previous rider takes-off from the zip line tower or the Zip Master signals for them.
 8. Rider should make use of the handrails and use caution as they ascend the staircase.
 - a. Queuing on the staircase is not allowed.
 9. Rider is directed by the Zip Master to the appropriate launch bucket.
 - a. Opposite bucket from the previous rider.
 - b. Zip Master directs rider to stand on the center step and face them.
 - c. Zip Master needs to be cognizant of the trolley returning behind him (the bucket opposite of the current rider).
 10. Zip Master reconfirms that the rider is properly harnessed.
 11. Zip Master reconfirms that the rider understands the warning and rules that appear on the Warning and Rules sign, as previously explained.
 12. Rider is connected to the trolley lanyard.
 - a. Carabiner is placed thru the 2 red chest straps on the harness.
 - b. The carabiner is connected to the highest loop possible on the trolley lanyard.
 - c. **Be sure that you hear the carabiner click into the locked position!**
 13. Zip Master visually double-checks the following before opening the launch bucket:
 - a. Auto-Retract® brake line is properly secured to the trolley cart.
 - b. Lanyard is connected to the trolley.
 - c. Carabiner is properly connected to the lanyard and harness.
 14. Zip Master instructs the rider regarding the proper protocol to follow during and after the zip ride. This includes the following:
 - a. Put both hands on the trolley or around the lanyard if you are not tall enough.
 - b. Never attempt to grab the steel ride cable or Auto-Retract® brake line at any time.
 - c. Take a natural step off the platform. **Do not jump up as you leave the Mobile Zip Line™ platform.**
 - d. Do not bounce while descending the Mobile Zip Line™.
 - e. Keep your eyes and body focused towards the landing area.
 - f. Keep your feet up & in front of you in a "Crunch" position while approaching the ground.
 - g. Once you have stopped, put your feet down and stand to facilitate unloading.
 - h. The rider should wait for an employee to disconnect them from the zip line.
 15. Zip Master double-checks that the cable line is free from other riders or obstructions.
 16. Zip Master rotates the launch bucket to the take-off position.
 17. Rider leaves the tower platform and travels down the zip line.
 18. Zip Assistant disconnects the rider from the trolley lanyard once they arrive at the bottom of the ride.
 19. Zip Assistant directs the rider to exit the Landing Zone. Pay special attention to avoid other Mobile Zip Line™ riders who may be descending on adjacent lines.
 20. As directed by the operator return to a safe area where the operator can assist with removing the harness.
 21. Make sure that the area is clear below the tower and launch buckets.
 22. Verify that the zip line area is clear before hooking up another zip rider.



Attention!

Although helmets are not required, we strongly recommend their use.

2.3 Emergency Evacuation Plan

In the event that a rider becomes stranded mid-line, the following emergency evacuation plan **MUST** be implemented:

1. Pull the Auto-Retract® line towards the tower to see if the trolley will roll backwards. This may be all that is needed to free an obstruction that may be jammed in the trolley preventing forward movement. Then allow gravity to carry the rider to the ground
2. If the trolley will not move forward, but it can be pulled backwards toward the tower, retrieve the rider by pulling on the Auto-Retract® brake line until the rider has been pulled back to the launch bucket.
3. If the trolley has become wedged, and will not move in either direction, call the local fire department. A bucket truck or ladder truck can be used as deemed appropriate to retrieve a stranded rider.

3. PRODUCT SETUP

This section of the manual will explain the operational procedures and practices for setting up the Mobile Zip Line (Gen III) product. This setup process consists of the following steps:

1. Identify a safe operating area.
2. Remove the Zip Line from the vehicle.
3. Pin the operator's safety rail.
4. Connect the steel cables to the tower.
5. Raise the tower.
6. Stabilize the tower.
7. Reposition the hitch.
8. Lock the tower mast upright.
9. Connect and tension the guy line cables.
10. Prepare the anchor gear.
11. Measure the anchor distance.
12. Unroll and inspect the ride cables.
13. Setup the anchors.
 - a. Using 2 vehicles as anchors.
 - b. Using a D.A.S.H. device as an anchor.
 - c. Using a water ballast as an anchor.
14. Setup the inflatable targets.
15. Inspect the Auto-Retract safety system.
16. Prepare the tower gear.
17. Setup the employee safety connection.
18. Setup the trolley inspection connection.
19. Attach the rider lanyard.
20. Attach the Auto-Retract brake rope to the trolley.
21. Prime the Auto-Retract safety system.
22. Fence off the area.

3.1 Identify an Operating Area

A safe operating area will contain the following attributes:

- Firm, level, and dry ground ONLY.
 - Grass, gravel, dirt, asphalt, & concrete are okay.



Figure 3. Find a Safe Area

- The area should be free of overhead obstacles.
 - Steer clear of power lines.
- Consider allocating space for harnessing.
- Do not operate in adverse weather conditions.
 - NO winds over 30mph.
 - NO lightning.

3.2 Remove the Zip Line from Vehicle

Complete the following steps to remove the Zip Line from the Vehicle:

1. Unplug the 7-pin electrical plug.
2. Unhook the safety chains and safety brake wire.



Figure 4. Remove Zip Line from Vehicle

3. Remove the trailer coupler pin and slide it to the open position.
4. Drop the jack extension leg as far as possible & insert the pin.
5. Crank the jack until the coupler is free of the ball hitch.
6. Pull the vehicle away from the trailer.

3.3 Pin the Operator's Safety Rail

This support arm is located on the center of the tower mast between the cables, and it pivots to reduce the overall transport height of the ride. Position one employee on the ride near the tower mast to completely pin the operator's safety rail and connect the steel cables to the tower while the ride is still lowered on trailer (see Section 3.4 for more information on connecting steel cables to the tower).



Figure 5. Pin the Operator's Safety Rail

Complete the following steps to properly pin the operator's safety rail into place:

1. Remove the pin.
2. Rotate the arm upwards.
3. Pin Operator's Safety Rail in place.

3.4 Connect the Steel Cables to the Tower

Complete the following steps to connect the steel cables to the tower:

1. Remove the 2 steel ride cables from the tool box.
2. Remove the 2 steel guy lines from the tool box.
3. Place the large loop of ride cable around the tower mast.



Figure 6. Loop Cable Around Mast

4. Connect the ride cable by placing the pin thru the thimble and securing with the r-clip.



Figure 7. Secure the Ride Cable with Pin

5. Inspect the guy line cable (see page30) and attach (not turnbuckle end) to the tower mast by likewise placing the pin thru the thimble and securing it with the r-clip.
6. Ensure that the guy line cable is positioned to the outside of the large loop of the ride cable.
7. Disconnect the Auto-Retract® rope from the travel position, thus allowing it to retract into the pulley.

3.5 Raise the Tower

Your Mobile Zip Line™ is equipped with a 12-volt hydraulic lift system powered by 2 onboard 12-volt batteries, 1 lift pump, and 1 lifting cylinder. Complete the following steps to raise the tower:

1. Position rubber pads under the stair feet if operating on asphalt (this prevents damage to structure paint).
2. Connect 2-button pendant to the receptacle on driver's side of trailer.



Figure 8. Use the Pendant to Raise the Tower

3. Press and continue holding the “Up” button until tower mast barely makes contact with the bucket structure.
4. Immediately remove the 2-button pendant and store it in tool box.

3.6 Stabilize the Tower

Complete the following steps to stabilize the tower:

1. Extend outrigger jacks.



Figure 9. Adjust the Jacks

2. Lower the jack drop legs as far as possible.
3. Jacks should make contact with the ground, and then be tightened another 5-10 turns of the handle.
4. Wheels should retain their full contact patch with the ground.
5. Position chocks front and back of the wheels, as pictured, on each side of the trailer.



Figure 10. Using Wheel Chocks

6. Place wheel lock between the wheels on each side.

3.7 Reposition the Hitch

During zip line operations, the hitch must be repositioned to gain access to the staircase. Complete the following steps to reposition the hitch:

1. Remove the clip and pull the hitch pin upward and out.
2. Swing the entire hitch assembly to the side.
3. Lower the jack leg just far enough to keep the hitch from moving.
4. Replace the hitch pin so you don't lose it.

3.8 Lock the Tower Mast (Upright)

Complete the following steps to properly lock the tower mast in an upright position:

1. Position an employee at the top of the stairs and locate the 2 yellow locks on either side of the mast.

2. Remove the yellow locks from the transport position where they are hooked around the bucket handles
3. Rotate the locks around the tower mast and pin them in place.



Figure 11. Yellow Mast Locks

If you are having difficulty with the pinhole alignment, it is possible that you may need to make small adjustments to the tower mast position.

1. Remove employee from the tower.
2. Use 2-button pendant to slightly adjust tower mast position up or down.

3.9 Connect and Tension the Guy Lines

2 guy line cables run from the top of the tower, parallel to the stairs, and connect to the trailer near the front pivot. They are a critical component. Complete the following steps to connect and tension the guy line cables:

1. Pin the turnbuckle to the trailer.



Figure 12. Pin the Turnbuckle to the Trailer

2. Use the turnbuckle to tighten the guy lines.
3. The guy line should have no more than 6" of deflection at the midpoint of the stairs.



Figure 13. 6" Deflection

3.10 Prepare the Anchor Gear

Several items must be moved from the trailer to the anchor area. You may find it helpful to place these items in the truck bed for easy transportation:

- 2 Automatic Tensioning Devices (ATDs).
- Tire chocks (if anchoring with vehicle).
- 2 Inflatable targets and blowers (if applicable).
- Dual Anchor Single Hitch (D.A.S.H.) attachment.
- Water ballast tank and frame (if applicable).

3.11 Measure the Anchor Distance

Complete the following steps to properly measure the anchor distance:

1. Connect the included measuring tape to the hook on the back of the trailer.

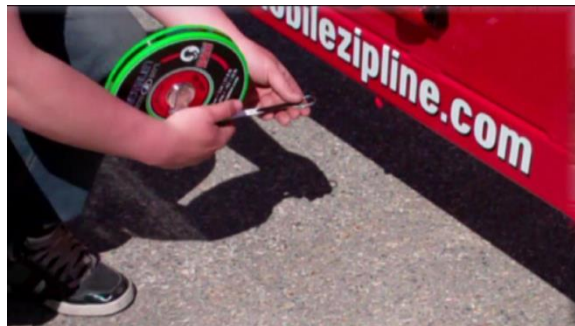

Figure 14. Measure the Anchor Distance 1

2. Pull the truck forward and unload 2 inflatable targets and blowers about 90' from trailer.
3. Measure to 142'- 6". This will be the distance from the back of the trailer to where the ATDs connect to the anchor(s).

3.12 Unroll and Inspect the Ride Cables

Carefully unroll the steel ride cables by hand or by using the Cable Reel. At this time inspect the cables (see the section titled “Rope & Cable Inspection”). Be sure to work out any twists in the cable, this will prevent kinking and bird caging. **Cables should always be handled with care.**



Figure 15. Unroll the Ride Cables

3.13 Setup the Anchors

Spectrum Sports Intl offers several engineered anchor solutions to meet the needs of various markets and the requirements of several regulatory agencies. Please check with your local governing body to determine what is permissible in your area.

3.13.1 Setting Up 2 Anchor Vehicles

Requirements: **Each anchor vehicle** must have a curb weight of **7000 lbs.** (3175 kg) **and** a **Class 3** or greater 2” receiver hitch.

Complete the following steps to setup 2 anchor vehicles for the Mobile Zip Line (Gen III) product:

1. Position the 2 vehicles side-by-side so that the receiver hitches are 142'-6" (43.4m) from the end of the trailer as measured with the included tape.



Figure 16. 2 Anchor Vehicles

2. The distance between the 2 anchor vehicles should be parked 10'- 15' (3 – 4.5m) apart when measured from **hitch-to-hitch**. This will allow adequate space between cables for the optional inflatable targets.
3. Install an Auto-Tensioning Device (ATD) into the receiver hitch of each vehicle and secure with a hitch pin and R-clip.



Figure 17. Install an ATD

4. Remove the pin from the lower portion of the **handle** on the ATD. This single hole in the handle will be the main connection point for the steel zip line ride cable.
5. Remove the pin from the lower series of holes that are arrayed in a half circle pattern
6. Connect the steel ride cable:
 - a. One employee will pull the handle towards the tower.
 - b. Another employee will pull the steel ride cable towards the ATD.



Figure 18. Attaching a Cable to the ATD

- c. Place the thimble end of the cable thru the handle and pin it. Be sure to install the "R" clip pin.



Figure 19. Pin the Cable to the ATD

- d. Release the handle after the cable is pinned allowing the ATD to properly tension the cable.



Figure 20. Connected ATD Cable

- e. The optimal position for the ATD handle at this point is very near 90°. The ATD gas shocks should not be fully extended allowing the handle to rest on the hitch side of the device. To micro adjust:
 - i. Unhook the zip line cable and move the tow vehicle a few inches as needed
 - ii. **Never move the vehicle while the cable is connected to the ATD!**
 - f. Now that the zip line cable has been properly tensioned, place the lower pin thru any set of aligned holes to lock the tension. Be sure to install the “R” clip on the pin.
 - g. Connect the back-up cable leg to the hitch safety chain loop on the vehicle using a rated quick link
7. Immediately secure the anchor vehicles by completing the following:
 - a. Place the vehicles in “park” for automatic transmissions or in 1st gear for a manual.
 - b. Remove the ignition keys and place in the tool box of the Mobile Zip Line™ trailer.
 - c. Set the vehicle “Emergency Brake”.
 - d. Place wheel chocks behind the rear tires.
 8. Continue to disable the vehicle by choosing **2** of the following actions:
 - a. Install a steering wheel lock.
 - b. Place a “Caution” sign over the steering wheels.
 - c. Lock the vehicle doors.
 - d. Disconnect a battery cable or engage a battery disconnect switch.
 - e. Place a wheel boot on the anchor vehicle.

3.13.2 Using a D.A.S.H. Device

It is possible to anchor the Mobile Zip Line™ with 1 vehicle and a Dual Anchor Single Hitch (DASH) adapter device.

Requirements: **Anchor vehicle** must have a curb weight of **7000 lbs.** (3175 kg) and a **Class 3** or greater 2” receiver hitch. Only OEM DASH components should be used.

Complete the following steps to use a D.A.S.H. as an anchor:

1. The DASH allows for a small degree of misalignment between the zip line structure and tow vehicle, but position the anchor vehicle as closely in line with the zip line trailer as possible.
2. Measure out 142’-6” (43.4m) from the end of the trailer to the receiver hitch on the anchor vehicle.
3. Attach the center mount plate of the DASH to the receiver hitch of the vehicle and secure with a hitch pin and R-clip.

4. Attach the 2 pivoting arms to the center mount plate using the 2 large pins and be sure to secure in place with the R-clips.



Figure 21. D.A.S.H. Anchor

5. Lower the stabilizer jacks on the pivoting anchor arms and secure with the U-pins.
6. Place the yellow wheel chock bar in front of the rear axle and adjust the chocks so that the alignment tab is pressed snug against the inside of the tires. (On dual axle vehicles the tab should be pressing against the inside of the outer tire.)



Figure 22. Yellow Chock Bar

7. Stretch a rated chain on each side between the notches located on the outer ends of the pivoting arms and wheel chock. (For initial setup adjust the chain length so that the arms are perpendicular.)
8. Attach the ATDs to each pivoting arm following the instructions in 13A, steps 3 thru 6d
9. The optimal position for the ATD handle at this point is near 90° or vertical. The ATD gas shocks should not be fully extended allowing the handle to rest on the hitch side of the device. If the gas shocks are fully extended you may need to slightly tighten the cable line.
 - a. Remove the chain from the notch on the wheel chock and retain a firm grasp on it.
 - b. Another employee should assist by slowly pushing the pivoting arm in the direction of the vehicle to tighten the line.
 - c. Continue adjusting the pivoting arm position until the ATD handle is near 90°.



Figure 23. ATD Pivot Arm

- d. Place the chain back in the notch on the wheel chock to retain this tension level.
- e. Now that the zip line cable has been properly tensioned, connect the loose chain ends back to the tightened cable using the included quick-links.



Figure 24. Connect Loose Chain Ends

10. Attach the backup cable leg to the quick-link on the end of the chain.

3.13.3 Using a Water Ballast Anchor

The Spectrum Sports Intl Water Ballast Anchor is designed to replace a 7000 lbs. (3175 kg) vehicle in the setup process. It may be used in several approved configurations:

- 1 Water Ballast for 1 zip line cable.
- 1 Water Ballast & 1 Vehicle for 2 zip line cables.
- 1 Water Ballast & the DASH for 2 zip line cables.

Complete the following steps to install a water ballast anchor:

1. Remove the vinyl tank and steel support frame from the transport location on back of the zip line trailer.
2. It is easier to drop the tank frame in the approximate location before positioning the zip line trailer.

3. Measure out 142'-6" (43.4m) from the end of the trailer to the front of the Water Ballast frame.
4. Assemble the steel support frame
 - a. Layout the 2-bottom side base pieces.
 - b. Stack the floor on the base pieces.
 - c. Stack the front frame section on the side base pieces with the receiving hitch facing the zip line tower.
 - d. Reconfirm the measurement of 142'-6" (43.4m) from the end of the trailer to the receiver hitch on the support frame.
 - e. Stack the rear frame section on the base.
 - f. Insert the side bars.
 - g. Stack the 2 top side pieces.



Figure 25. Water Ballast Anchor

5. Unroll the tank and hang on the frame hooks.
6. Fill with water to the top of the tank.
7. Secure the optional vinyl cover over the tank.
8. At this point cable attachment will depend on the configuration.
 - a. See 3.3.1, 3-6 if anchoring a single line.
 - b. See 3.3.2 if anchoring both lines with a DASH.

3.14 Setup the Inflatable Targets

The Inflatable Targets add an element of fun to the Mobile Zip Line™. They are not intended as stopping devices. They are purely cosmetic in nature, and an operator may choose to omit their use.

Complete the following steps to setup the inflatable targets:

1. Remove the inflatable targets and blower(s) from the transport location on the zip line trailer.
2. It may be easier to transport these items from the trailer to the setup location by placing them in the back of your tow vehicle as outlined in 3.10.
3. Measure out roughly 90' from the end of the trailer to the front of the inflatable targets.
4. Remove from storage bags, unfold, and position each inflatable under a zip line cable.
5. Unfasten the Velcro straps on top of the targets.
6. Pull the Velcro straps over the top of the cables and refasten **AFTER THE CABLES HAVE BEEN PROPERLY TIGHTENED.**

7. Connect the inflatable blowers (not included) to the inflate tubes located on the back of the targets.
 - a. 2 separate 1/4hp blowers may be used to inflate the targets.
 - b. A single 1hp or greater blower may be used to inflate both targets if they are connected in series using the extra rear inflate tubes.
 - c. All blowers should be connected to a grounded power source.
8. Inflate targets.
9. Position targets so that the zip line cables do not rub on the inside of the target notches.



Figure 26. Inflatable Targets

10. Position targets so that a maximum weight zip line rider will stop just short of touching the target. This may take some testing & adjustment.
11. Anchor the 4 corner straps with stakes, ground weights, or sandbag ground anchors.
12. Keep the inflatable targets clean and dry.

3.15 Inspect the Auto-Retract

The following inspection must be completed for each Auto-Retract® safety system before the zip line is put into daily operation.

1. Remove the transport straps from the Auto-Retract® trolley cart.

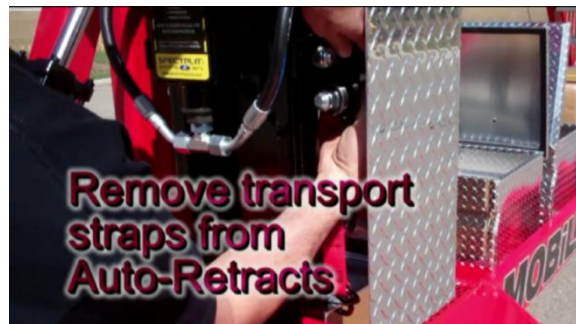

Figure 27. Remove the Auto-Retract Straps

2. Check the air pressure gauge to confirm that it reads within the safe operating range or 55-65 psi.
 - a. Air may be added via the Schrader valve stem opposite the gauge.



Figure 28. Check the Auto-Retract Pressure

3. Check the oil sight eye for fluid. It is dyed a blue color and must register as visible in the bubble sight eye.



Figure 29. Auto-Retract Bubble Sight Eye

To add oil:

- a. First release the air pressure using the previously mentioned Schrader valve.
- b. Remove the cap on top of the tank.
- c. Slowly add ISO 32 hydraulic fluid until the fluid level is visible in the sight eye. There should be enough residual blue dye in your tank to change the naturally golden color of the new fluid to blue.
- d. Replace the cap on top of the tank.
- e. Re-pressurize the tank to 55-65 psi by adding air to the previously mentioned Schrader valve.



Attention!

Additional Auto-Retract® preparation will be addressed later and must be performed before the unit will be ready for use.

3.16 Prepare the Tower Gear

Remove the tower gear from the tool box and sort the items in preparation for ascending the tower stairs. The tower employee will attach this gear to the tower after setting up the employee safety connection (see Section 3.17).



Figure 30. Tower Gear

Your tool box should contain the following items:

- 2 Trolleys.
- 2 Rider Lanyards.
 - Attach a steel auto-locking carabiner to the large grey loop, red loop, and any one of the smaller daisy chain loops.
- 1 Full-Body Harness for operator.
- 1 Operator Lanyard.
 - Attach a steel locking carabiner to each end.

3.17 Setup the Employee Safety Connection

It is good procedure, and the requirement of several regulatory agencies, that the tower employee should always wear a full body harness when working at heights.

1. The operator lanyard is connected to the d-ring on the back of the harness by carabiner or a simple hitch knot.
2. Connect this lanyard before putting on the harness, or have a second operator assist with the lanyard connection to the back d-ring.



Figure 31. Employee Harness

3. Operator ascends the tower stairs.
4. The operator lanyard is connected to the operator safety rail on the top of the tower.
 - a. Thread the end of the lanyard over the bar on the operator safety rail.
 - b. Connect the end of the lanyard to itself using a steel locking carabiner.
 - c. The operator lanyard should not have slack.



Figure 32. Connect the Employee/Operator Lanyard

Now that the tower employee is safely secured they are free to complete the zip line setup.

3.18 Setup the Trolley Inspection Connection

Inspect the trolley before connecting. Verify that:

1. Steel connection points show no signs of wear (grooves or key-holing).
2. Bearings spin quietly and smoothly.

Complete the following steps to install the trolley:

1. The hole on top of the trolley carriage should be on the tower side.
2. Remove the R-clip and pin located part way down the trolley handle assembly, and keep in a safe and convenient place such as a pocket.
3. Split the trolley halves apart by pulling lightly on the handles.
4. Place the trolley over the cable and slide the halves back together.
5. **Keep a firm grasp on the trolley as it is free to roll down the zip line cable at this point!**

3.19 Attach the Rider Lanyard

Complete the following steps to attach the rider lanyard:

1. Attach the primary connection point of the lanyard (small red loop) to any of the 3 holes on the bottom of the trolley using a steel auto-locking carabiner.



Figure 33. Attach the Lanyard to the Trolley

Tip: Slip the bottom loop of the lanyard around the handle on the tower bucket to keep the trolley from rolling away. This will give you both hands to work with for the next step.

2. Attach the large back-up loop of the lanyard to the top hole on the trolley by opening the carabiner gate, clipping around the ride cable, and then threading the nose of the carabiner through the upper holes in the steel plates of the trolley.



Figure 34. Attach the Backup Loop

Tip: Lift the front pulley wheel up, which in turn lowers the rear connection hole which in turn makes this step significantly easier.

At this point you should have a primary connection and a loose back up lanyard connection.

3.20 Attach the Auto-Retract Brake Rope to the Trolley

Complete the following steps to attach the Auto-Retract brake rope to the trolley:

1. Thread the thimble loop of the Auto-Retract® brake rope through the carabiner of the backup lanyard connection and between the side-plates of the trolley (see photo).



Figure 35. Attach the Auto-Retract Brake Rope

2. Insert the pin from Step 18 thru the trolley side plates and the thimble loop of the Auto-Retract® rope and secure with the R-clip. Always pin the R-clip so that it's visible to the operator during use.

3.21 Prime the Auto-Retract

The Auto-Retract® braking device utilizes 2 hydraulic cylinders that absorb the energy of the zip line rider. These cylinders must be primed each day before opening the zip line or between cycles of raising/lowering tower.

1. The tower operator will pull out the Auto-Retract® rope by hand as gravity carries the trolley down the line.
 - a. The tower employee will inspect the rope as he pulls it out from the device.



Figure 36. Tower Employee – Auto-Retract Priming

- b. The ground employee will check that the rope is traveling freely thru the pulley blocks below on the trailer.



Figure 37. Ground Employee – Auto-Retract Priming

2. The tower employee will eventually encounter resistance as he pulls out the rope. This is the braking portion of the ride which compresses the mechanical springs and hydraulic cylinders of the Auto-Retract®.
3. The tower employee will prime the Auto-Retract® cylinders by pulling on the rope through this resistance phase until the rope will no longer spool out.
Tip: It may be easier to have an employee on the ground pull the rope out through this resistance phase.
4. Let the rope retract back into the device 18ft (5.5m), and then repeat step 3. This should be repeated 3 times or until you are satisfied that the hydraulic cylinders are producing consistent resistance.
5. Allow the Auto-Retract® rope to fully retract into the device.
6. Repeat on the other zip line cable as each line has its own independent Auto-Retract® braking device.

3.22 Fence Off the Area

Check with your local governing body to determine what is required in terms of fence style. You may or may not be required to use ASTM event fencing in your area. We require that you at a minimum safely secure the Landing Zone (Example A). This is the 65' x 20' (20m x 6m) area from the inflatable targets forward towards the trailer. At least one rider exit should be located on either side of this fenced area. Some local governing bodies may require you to fence a larger area such as Example B.

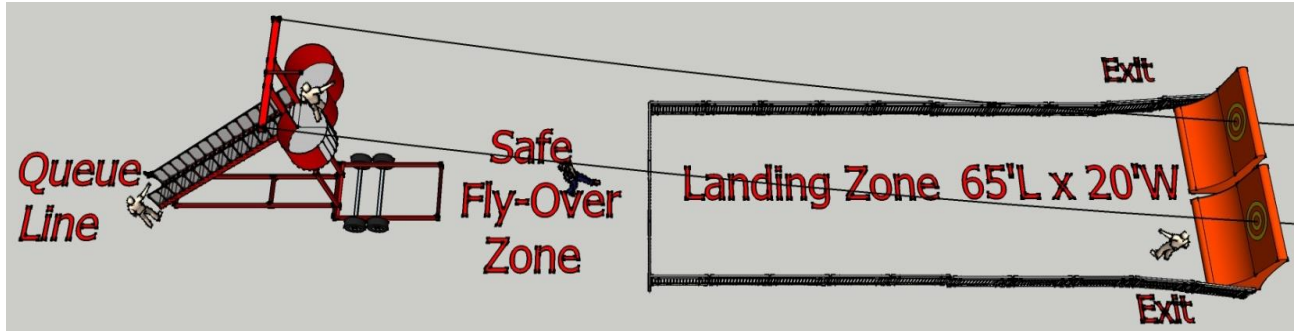

Figure 38. Fencing off the Area (Ex. A)

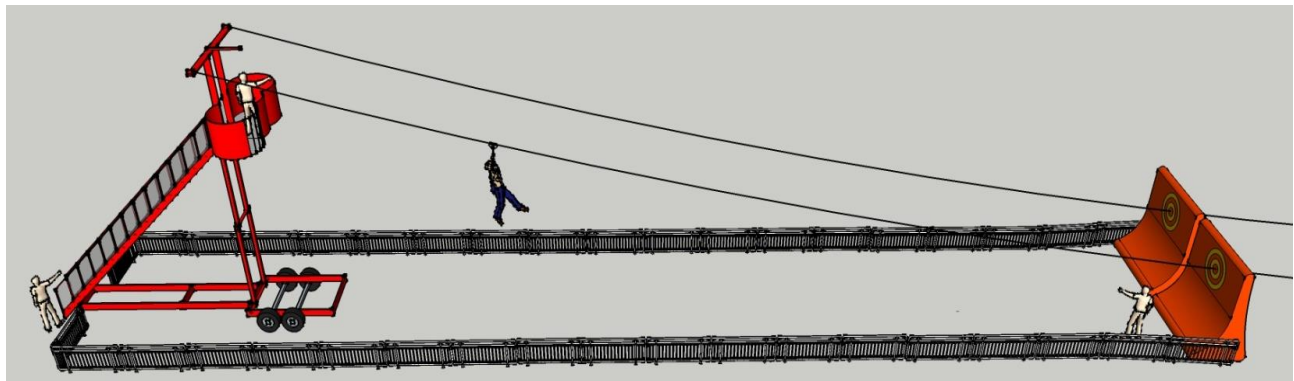

Figure 39. Fencing off the Area (Ex. B)

Fencing stores nicely on the Mobile Zip Line™ stairway when the trailer is in the transport mode.

4. INSPECTIONS AND MAINTENANCE

This section of the manual will provide you with guidelines and checklists for daily, quarterly, and yearly inspections. This section will also provide you with guidelines for other product-related inspections.



Warning!

Inspections of the Mobile Zip Line (Gen III) must occur on a daily, quarterly, and yearly basis to ensure continued, safe operation. These guidelines are a minimum. Take caution to ensure that any and all working parts and safety related products are thoroughly inspected and that all bolts and pins are secure before use.



Attention!

All of the information in this chapter of the manual must be understood and implemented. All of the inspections listed in this section must be performed within the time frames specified by this manual.

4.1 Time Based Inspections

4.1.1 Daily Inspections

On the Mobile Zip Line (Gen III) product, no component will fail without first revealing warning signs due to wear or damage. Daily inspections should be sufficient to find any potential problem well before failure becomes imminent. The Daily Inspection checklist should be followed and completed on a daily basis.

You may download a Daily Inspection checklist from www.spectrumsports.com.

4.1.2 Quarterly Inspections

On the Mobile Zip Line (Gen III) product, no component will fail without first revealing warning signs due to wear or damage. Three-month inspections should be sufficient to find any potential problem well before failure becomes imminent. The Quarterly Inspection checklist should be followed and completed on a three-month basis.

You may download a Quarterly Inspection checklist from www.spectrumsports.com.

4.1.3 Yearly Inspections

On the Mobile Zip Line (Gen III) product, no component will fail without first revealing warning signs due to wear or damage. Yearly inspections should be sufficient to find any potential problem well before failure becomes imminent. The Annual Inspection checklist should be followed and completed on a yearly basis.

You may download the Annual Inspection checklist from www.spectrumsports.com.

4.2 Inspection Checklists

The next few pages will contain inspection checklists that **MUST** be completed to ensure safe operation.

4.2.1 Quick Reference Checklist

Table 2. Quick Reference Checklist

INSPECTION ITEM	DAILY	QUARTERLY	YEARLY
Operating Area	X		
Tower Locks	X		
Guy Cables	X		
Steel Ride Cables	X		
Inflatable Targets (If Applicable)	X		
Auto-Retract Ropes	X		
Auto-Retract Air Pressure	X		
Auto-Retract Hydraulic Fluid	X		
Auto-Retract Priming	X		
Lanyards	X		
Auto-Locking Carabiners	X		
Trolleys	X		
Compression Damping Coil Springs		X	
Pulleys and Pulley Cart		X	
Auto-Retract Hydraulic Hoses		X	
Hardware		X	
Visual Inspection		X	
Clean the Mobile Zip Line (Gen III)		X	
Replace Steel Ride Cables			X
Replace Auto-Retract Ropes			X
Replace Critical Hardware			X

4.2.2 Daily Inspection Checklist

Table 3. Daily Inspection Checklist

DAILY INSPECTION CHECKLIST		
Operator: _____		
Date: _____		
<input type="checkbox"/>	Operating Area Firm, level, and dry ground. Free of overhead obstructions. Winds under 30mph. No lightning.	
1	2	Tower Locks Positioned and locked around tower mast for operations.
1	2	Guy Cables Inspect for flat spots, broken strands, twists, kinks, or bird-caging (page 30). Properly tensioned for operations (page 11).
1	2	Steel Ride Cables Inspect for flat spots, broken strands, twists, kinks, or bird-caging (page 30). Properly connected and tensioned for operations (pages & 12-13).
1	2	Inflatable Targets (if used) Properly anchored with stakes, ground weights or anchors, or sandbags. Blower(s) is connected to a grounded power source.
1	2	Auto-Retract® Ropes Inspect for cuts and frays. Inspect knots on each end: should be figure-8 with at least 2" tail or sewn end. Properly connected to trolley (page 19).
1	2	Auto-Retract® Air Pressure Check each air pressure gauge to confirm that they read in the range of 55-65 psi. <i>Write the actual reading in the box to the left, not a check mark!</i>
1	2	Auto-Retract® Hydraulic Fluid Blue-tinted hydraulic fluid should be visible in the oil sight eye when the tower is upright.
1	2	Auto-Retract® Priming Ensure that the Auto-Retract® has been properly primed (page 19)
<input type="checkbox"/>	Lanyards Inspect the 2 rider lanyards and 1 operator lanyard to ensure that there are no cuts, frays, or loose stitching.	
<input type="checkbox"/>	Auto-Locking Carabineers Inspect for surface rust, pitting, or any wear in the metal. Gate automatically snaps closed.	
1	2	Trolleys Connection points should not show signs of wear (grooves or key-holing). Bearings spin freely and quietly. Properly installed on ride cables (page 18).
© Copyright Spectrum Sports Intl. 888-563-0163. Service@SpectrumSports.com		

4.2.3 Quarterly Inspection Checklist

Table 4. Quarterly Inspection Checklist

QUARTERLY INSPECTION CHECKLIST	
Operator: _____	
Date: _____	
<input type="checkbox"/>	In addition to Daily Inspections:
<input type="checkbox"/>	1 2 Compression Damping Coil Springs
<input type="checkbox"/>	<input type="checkbox"/> Check for cracks or signs of wear or fatigue.
<input type="checkbox"/>	1 2 Pulleys and Pulley Cart
<input type="checkbox"/>	<input type="checkbox"/> Check all pulleys (including 2 on tower) for wear, chipping, or cracking. Ensure that the pulley cart is free from debris, and make sure that it is not obstructed in any way. Check bearing wheels for signs of wear and conform there is proper contact with the track.
<input type="checkbox"/>	1 2 Auto-Retract® Hydraulic Hoses
<input type="checkbox"/>	<input type="checkbox"/> Inspect for leaks around the fittings. Tighten and document any alterations to the system.
<input type="checkbox"/>	1 2 Hardware
<input type="checkbox"/>	<input type="checkbox"/> Inspect the following critical hardware: 12" bolts thru pulleys on the Auto-Retract®, 2 bolts thru tower pulleys, bent-pull pins (4 on tower, 4 on ATDs).
<input type="checkbox"/>	1 2 Visual Inspection
<input type="checkbox"/>	<input type="checkbox"/> Visually inspect all structural components and welds for damage, deflection, or cracking.
<input type="checkbox"/>	1 2 Clean the Trailer and Zip Line
<input type="checkbox"/>	<input type="checkbox"/> Use mild detergents.
© Copyright Spectrum Sports Intl. 888-563-0163. Service@SpectrumSports.com	

4.2.4 Annual Inspection Checklist

Table 5. Annual Inspection Checklist

ANNUAL INSPECTION CHECKLIST		
Operator: _____		
Date: _____		
<input type="checkbox"/> In addition to Daily & Quarterly Inspections:		
1	2	Steel Ride Cables
<input type="checkbox"/>	<input type="checkbox"/>	Replace both steel ride cables
1	2	Auto-Retract® Ropes
<input type="checkbox"/>	<input type="checkbox"/>	Replace both Auto-Retract® ropes. Inspect knots and connection points.
1	2	Hardware
<input type="checkbox"/>	<input type="checkbox"/>	Replace the following critical hardware: 12" bolts thru pulleys on the Auto-Retracts®, 2 bolts thru tower pulleys, bent-pull pins (4 on tower, 4 on ATDs).
<small>© Copyright Spectrum Sports Intl. 888-563-0163. Service@SpectrumSports.com</small>		

4.3 Inspecting Wear Items

The following components are wear items. It is up to the operator to monitor and determine when it is time for replacement based on the following guidelines. When in doubt, change it out!

- **Carabiners** – Replace if the auto-locking sleeve on the gate no longer snaps closed on its own. Surface rust, pitting, or wear grooves would also suggest the need for replacement.
- **Quick-Link** – Replace if the screw gate will no longer close. Surface rust, pitting, or wear grooves would also suggest the need for replacement.
- **Pulleys** – Inspect the v-groove for wear and ensure that pulleys roll smoothly on bearings.
- **Trolley** – Ensure that bearings roll smoothly and quietly. Inspect all carabiner and pin connection points for wear. Connection holes that are oblong indicate that you should replace the trolley.
- **Auto-Retract® Cylinders** – Replace when you see excessive oil leakage (visible on every stroke).
- **Lanyards** – Replace when you see fraying or stitching coming loose.
- **Guy Cables & Turnbuckles** – Replace if inspection parameters reveal problems or if any surface rust or pitting appear. Guy cables must be used for safe operations!

4.4 Trailer Inspections



Attention!

Spectrum Sports Intl recommends the following minimum inspections for the Mobile Zip Line™ trailer. It is your responsibility to ensure that your trailer is road-worthy. Failure to comply will result in non-compliance and therefore no manufactures liability coverage will be available.

See the Trailer Inspection checklist on the next two pages.

4.4.1 Trailer Inspection Checklist

Table 6. Mobile Zip Line Trailer Inspection Checklist

INSPECTION ITEM	DAILY	QUARTERLY	YEARLY
Travel straps secured on Auto-Retracts®	X		
Tower lock secured around handles on buckets for transportation	X		
Ensure the entrance gate is locked for transportation	X		
Check hitch to ensure that pins are secure and in tow position	X		
Check tool box for contents and ensure lid is locked down	X		
Tire Pressure	X		
Lugs nuts	X		
Trailer Plug	X		
Trailer Lights	X		
Trailer Brakes	X		
2-Button Remote Pendant (be sure to have this before leaving for an event)	X		
Check Battery for full charge	X		
Trailer welds		X	
Pivot welds		X	
Spare Tire for air pressure (see tire for specs)		X	
Stair way and platform welds		X	
Hydraulic Hoses on the lifting pump for leaks		X	
Clean all steel and handrail		X	
Axle Brakes			X
Axle Bearings			X
Upper pivot, grease			X
Fluid in lifting pump (ISO 32)			X

INSPECTION ITEM	DAILY	QUARTERLY	YEARLY
Jacks- Grease & Lube if needed			X
Hydraulic Lifting cylinders on trailer-check welds			X

4.5 Rope Inspection Guidelines

WARNING

THE IMPROPER USE OF ROPE IS

DANGEROUS

FIBER ROPE WILL FAIL IF WORN, DAMAGED, ABUSED, OVERLOADED OR NOT PROPERLY MAINTAINED.

Rope Failure Can Cause Serious Injury or Death.

**Please read this
before using any
fiber rope**

- USER is responsible to determine suitability of a rope for specific applications.
- KNOW the working load limit (WLL) of your rope. Get WLL from manufacturer or supervisor.
- USE ONLY rope in good condition, without cuts or pulled strands.
- DO NOT exceed WLL or shock load.
- DO NOT stand within recoil (snapback) area.
- DO NOT use over rough surfaces without chafe protection.
- USE sheaves with a minimum of 8 times the rope diameter.
- DO NOT bend around unprotected, sharp, corners.

*There are many standards and guidelines for the use of rope in specific applications.
Contact the Cordage Institute: 994 Old Eagle School Road, St. 1019, Wayne, PA.
19087-1866. Tel: 610-971-4854; Fax: 610-971-4859; Email: info@ropecord.com*

SPECTRUM SPORTS INTL

324 W 2500 N Bldg A | North Logan, UT 84341 | 888-563-0163

Figure 40. Rope Inspection Warnings

FOLLOW THESE RULES FOR SAFETY AND GOOD CARE OF ROPE



Make sure your rope size is adequate for the job. **DON'T USE TOO SMALL A ROPE.** A table of specifications is available from your dealer, distributor, or the manufacturer.



Keep rope clean. Don't drag rope over ground or other rough gritty surfaces. This allows abrasive particles to work into the rope and damage fibers.



Uncoil rope properly. Lay coil flat with Inside end of rope nearest the deck. Loosen lashings and covering. Reach down through center of coil and pull rope up through from inside the coil.



Prevent kinks, which cause permanent damage and weakening of the rope. If rope is continually twisted in one direction, as over a winch, counteract by throwing in twist in opposite direction.

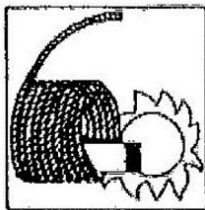

Dry rope before storing. Manila ropes mildew and decay if stored wet; a cool, dry room with free air circulation provides the best storage. Do not store in direct sunlight.

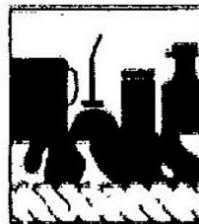

Protect rope from chemicals such as acids, alkalis, oils, paints and other agents not chemically neutral.



Reverse rope ends regularly, particularly when used in tackle. This permits even wearing and assures longer useful life.



Avoid sudden strains. Shock loading, as jerking, may cause failure of a rope normally strong enough to handle the load. When using tackle or slings, apply a steady, even pull to get full strength from rope.

CAUTION: Heat can seriously affect the strength of synthetic ropes. The temperature at which a 50% strength loss can occur are:
 Polypropylene: 200 F Nylon: 300 F Polyester: 350 F
 Kevlar/Technora: 400 F Dyneema/Spectra: 150 F

Figure 41. Rope Inspection Guidelines

4.6 Cable Inspections

A rigorous inspection routine is not only recommended, but required. Proper inspection will eliminate the chance of using a wire rope beyond its useful life. The inspection routine listed is the procedure that should be followed rigorously. This inspection method is visual and adheres to the applicable standards published in the United States.

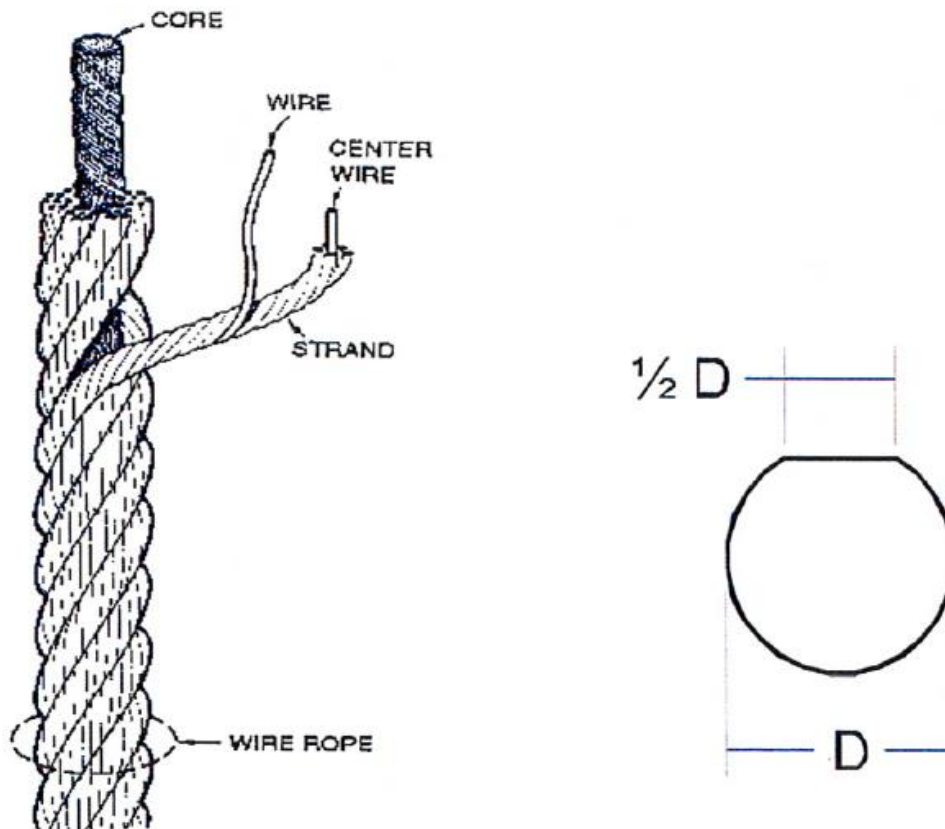

Figure 42. Single Wire Inspection Criteria for Wire Ropes.

4.6.1 Replacing the Cable

Replace the cable if any of the following conditions are true (refer to the previous figure):

1. If any of the individual wires in a strand have a flat spot of more than $\frac{1}{2}$ the diameter of the smallest wire as shown in the figure above.
2. If there is a single broken wire in any strand.
3. If there are 50,000 or more cycles on the route.
4. If the cables have been on a climbing tower for 1 year (12 months).
5. If there are any twists, kinks, flat spots, or bird-caging.

The wire rope inspection criteria recommended by various agencies, manufacturers, and governing agencies in the United States have published guidelines pertaining to wire rope use, maintenance, inspection, and general specifications. Most wire rope manufacturers have additional guidelines for the use, maintenance, and inspection of their cables. These guidelines and codes set precedence for the industry standard methods of wire rope use, maintenance, and inspection. Deviation from these recommendations would be viewed as questionable by the most experienced engineers in the industry.

To justify the inspection method recommended by Spectrum Sports Intl, the most noted codes and guidelines have been obtained and read by SAE Inc. engineers. The codes obtained by SAE Inc. engineers include:

- **ASME (American Society of Mechanical Engineers) International Publication.**
ASME/B30.5c – Mobile and Locomotive Cranes, 1998, ISBN#: 0791822753
This code is a revision of the ASME/ANSI B30.5-1989. It applies specifically to applications similar to the Space Shot™ ride.
- **Wire Rope Technical Board**
Wire Rope User’s Manual, Third Edition, 1993
This test gives a summary compilation of the recommended practices for wire rope use in general applications.
- **OSHA Wire Rope Excerpts** – General Standards, Vol. 37, Number 202, Oct. 1972.
This general standard is a compilation of the ASME/ANSI standards that exist now as the SME/B30.XX series. These are the forerunner to current standards.
- **Leeschen Wire Rope Company**
“Wire rope Inspection”, Report #107.
This report gives guidelines to the inspection methods appropriate to identify wire rope damage.

Each of these codes specifies, in general, the same criteria for the inspection of wire ropes. Additional ASME codes specify inspection criteria for additional applications including, but not limited to, personnel hoists (elevators), overhead cranes, material hoists, etc. The ASME code governing *Mobile and Locomotive Cranes* is very stringent. It is the most stringent code that has any applicability to the Mobile Zip Line. The highlights of the inspection guidelines/codes listed above are included in the next table of this document to set a comparison reference for Spectrum Sports Intl guidelines.

Note: The inspection procedures outlined in the referenced codes are all *visual inspections*.

4.6.2 Cable Replacement Options

The following cable replacement options are available:

- **On-Site Service:** Spectrum Sports Intl has offered the option of On-Site Service for over a decade. Our service truck is fully equipped and circles the entire country twice each year. The On-Site Service option may include cable replacement, parts replacement, inspections, and any other maintenance needs pertaining to the customer’s request.
To be put on the On-Site Service schedule: visit our website at www.spectrumsports.com , then fill out, and submit the request form or call (888) 563-0163.
- **Self-Installation:** Customers who wish to install cables on their own product have the option of ordering certified cable, with both ends crimped, straight from our facility.

4.6.3 Wire Rope Inspection Comparison

A wire rope inspection criteria comparison can be seen in the table below:

Table 7. Wire Rope Inspection Comparison

INSPECTION CRITERIA REQUIRING ROPE REPLACEMENT	ASME/B30.5C CRANES	WIRE ROPE USERS GUIDE, 3 RD EDITION
Length of Wire Rope Service	No specifications given.	No specifications given.
Abrasion	1/3 diameter worn on any wire (see below).	1/3 diameter worn on any wire, see specific governing code.
Rope Stretch	No specifications given.	When the rate of stretch increases after initial break-in period.
Reduction in Rope Diameter	1/48" on cables 1/4" diameter.	When accompanied with significant rope stretch; otherwise not specific.
Corrosion	Not specified.	If accompanied by metal pitting; if rust exists.
Kinks, Twists, Crushing	Any – replace wire rope.	Any – replace unless cable is repairable.
“Bird Caging”	Any defect – replace unless defect can be removed.	Any defect – replace unless defect can be removed.
Heat/Electrical	Any – replace wire rope.	If wires are fused or discolored.
Broken Strands	Rotation resistant ropes: 2 wires in 6 rope diameters – and 4 wires in 30 rope diameters. New criteria: 4 broken wires in one lay-length and 2 broken wires within 1 strand within 1 lay-length.	See specific code.
Damaged End Attachments	If non-repairable, replace wire rope.	See specific code.
Non-destructive	Not specified	Not specified.

The ASME/B30.5 inspection criterion is very specific on the visual inspections required. The code is specifically designed to allow an inspector to accurately infer the status of the wire rope core from a thorough inspection of the wire ropes broken wires in a strand, abrasion of the wires in the strands, and the change in the diameter of the overall rope. The inspection criterion requires a thorough visual inspection of the rope.

The number of broken strands is a key aspect of all the ASME codes. Due to the primary role it plays in determining the integrity of the rope core, a summary of the ASME code allowable broken strands can be seen in the table below.

Table 8. Allowable broken strands by ASME Code

ASME STANDARD	EQUIPMENT CONNECTION	NUMBER OF BROKEN WIRES IN RUNNING ROPES		NUMBER OF BROKEN WIRES IN STANDING ROPES	
		IN ONE		IN ONE	
		ROPE LAY	STRAND	ROPE LAY	STRAND
ASME/B30.2	Overhead & Gantry Cranes	12**	4	Not Specified	
ASME/B30.4	Portal, Tower, & Pillar Cranes	6**	3	3	2
ASME/B30.5	Crawler, Locomotive & Truck Cranes: Retirement criteria based on number of broken wires rev B. Rotation Resistant Rope found in length of rope equal to 6x rope diameter – 2 broken wires maximum; and 30x rope diameter – 4 broken wires maximum.				
ASME/B30.5	Running Rope	6**	3	3	2
ASME/B30.6	Derricks	6**	3	3	2
ASME/B30.7	Base Mounted Drum Hoists	6**	3	3	2
ASME/B30.8	Floating Cranes & Derricks	6**	3	3	2
ASME/B30.16	Overhead Hoists	12**	4	Not Specified	
ANSI/A10.4	Personnel Hoists	6**	3	2**	2
ANSI/A10.5	Material Hoists	6**	Not Specified		

****Also remove for 1 valley break**

4.7 Maintenance

Spectrum Sports Intl will not warranty or be liable for any of its products, components, or safety systems that do not use genuine and/or authorized replacement parts. Any modifications, alterations, misuse, work, or service that is performed on your Spectrum Sports Intl Mobile Zip Line™ that is not performed by an authorized Spectrum Sports Intl employee voids any and all claims to any manufacturer's liability.

4.7.1 Cleaning

We recommend that you clean your Mobile Zip Line™ frequently. Use a spray nozzle and mild detergents and hand-dry thoroughly before storing.



Attention!

Use caution if you use a pressure washer to clean. DO NOT point the nozzle directly at the Auto-Retract®, lift pump, pivot points, grease points, or powder coat paint finish. You may damage the product. Do not use any mineral spirits, acids, or other harmful chemical products on your Mobile Zip Line™.

We recommend using a furniture polish without natural oils to help keep steel parts clean and polished. This type of product leaves a light layer of wax on the steel to protect it and refreshes the finish. This process also provides an opportunity to look at the welds and inspect the product. DO NOT USE POLISH ON THE STEPS OF THE ZIP LINE.

4.7.2 Product Storage (Winterization)

If you're Mobile Zip Line™ will not be in service for a period of 30 days or more, we recommend the following storage procedures.

- Remove Auto-Retract® brake ropes and store them in a dry location out of direct sunlight.
- Depressurize (release air pressure) from Auto-Retract® tanks.
- Disconnect battery cables from battery (disconnect ground cable first). Store the battery indoors (off the ground).
- Clean and properly store the inflatable targets (make sure they are dry).
- Keep all safety gear (trolleys, lanyards, carabiners, and harnesses) in a dry location.
- Store entire product under roof or tarp if possible.

If you have any questions or concerns, please call Spectrum Sports Intl at (435)792-3883, or email us at service@spectrumsports.com

4.7.3 Service Options

On-Site Service: Spectrum Sports Intl has offered the option of On-Site Service for over a decade. Our service truck travels the U.S. twice each year and is fully equipped. Service that aligns with the truck's schedule can be offered at a very competitive rate. The service offered may include cable replacement, parts replacement, inspection, and any other maintenance needs pertaining to the customers' request. To be added to the On-Site Service schedule, visit our website at www.spectrumsports.com to complete and submit the request form, or call (888)563-0163.

Self-Installation: Customers who wish to do their own maintenance have the option of ordering certified OEM parts directly from Spectrum Sports Intl. The customer then assumes all liability for the work, but the part is still covered by the manufacturer's warranty provided it is installed and used properly.

3rd Party Service: Spectrum Sports Intl does not train nor authorize 3rd party vendors to service its products. If any 3rd party purports to be an authorized Spectrum Sports Intl servicer, please report it to us immediately.

4.8 Non-Destructive Examination (NDE) Inspection Policy

Spectrum Sports Intl has had a third-party structural analysis for all of our products since 2004. These analyses call out for "visual inspections" for specific items.

Spectrum Sports Intl requires visual inspections of the applicable items as called out in the "Inspections" section of this product owners/operators manual.



Attention!

The documented daily, weekly, quarterly, and annual inspections must be completed to ensure safe operations of all products.

4.9 Mobile Zip Line Stickers

Be aware of the location of these stickers and follow their instructions.

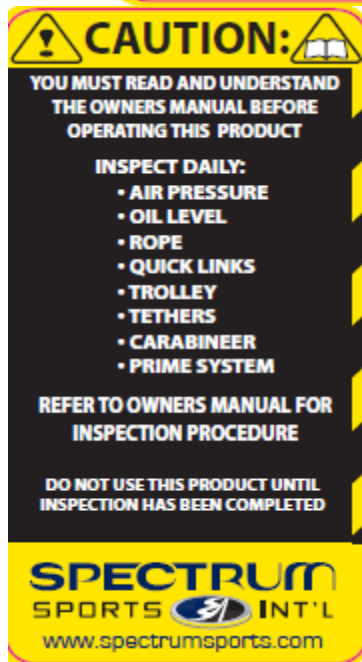

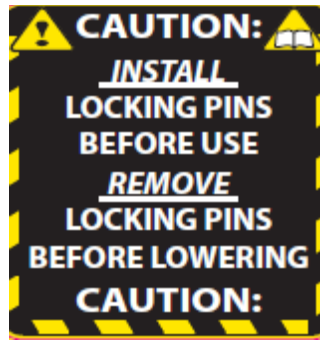

Figure 43. Mobile Zip Line Stickers

4.9.1 Auto-Retract® Stickers



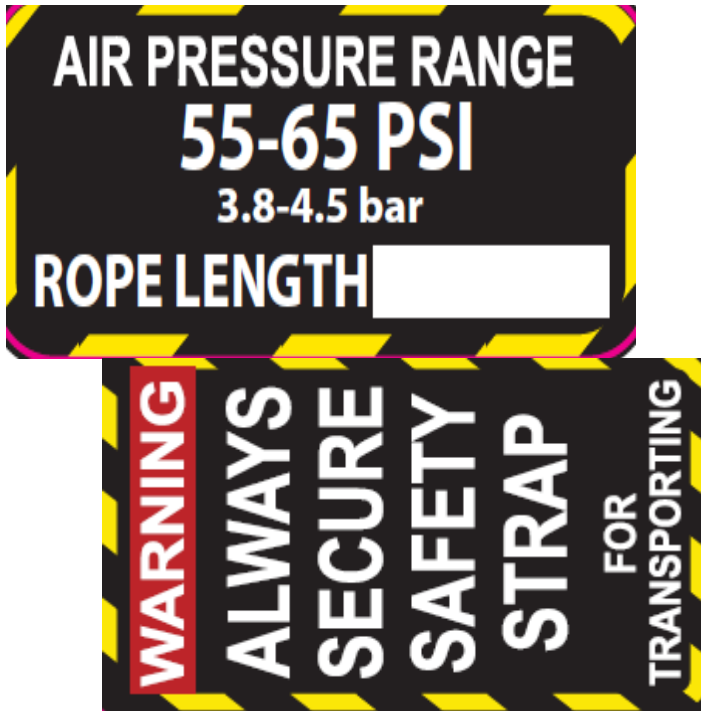

Figure 44. Auto-Retract Stickers

5. TAKE DOWN

This section of the manual contains instructions for properly taking down the Mobile Zip Line (Gen III) product. The steps for taking down the Mobile Zip Line (Gen III) are as follows:

1. Dismantle the inflatable targets.
2. Remove the trolley and lanyard.
3. Detach the cables from the ATDs.
4. Dismantle the Anchors
 - a. 2 Anchor Vehicles
 - b. D.A.S.H. anchor
 - c. Water ballast anchors
5. Store the cables.
6. Disconnect the guy lines.
7. Unlock the tower mast.
8. Prep the trailer for lowering.
9. Lower the tower.
10. Collect the remaining tower gear.
11. Prepare for transit.

5.1 Dismantle Inflatable Targets

The following steps need to be completed to start the tear down process.

1. Clean the inflatable from any foreign substance.
2. Ensure the inflatable is dry before putting away. **Never store wet!**
3. Let the air out of the inflatable, paying particular attention to ensure it does not hang on the cable.
4. Roll/Fold up inflatable to the appropriate size to fit it in the included bag.
5. Put the bag on the trailer and strap it securely.
6. Store the inflatable's blower on the trailer or in a tow vehicle.

5.2 Remove the Trolley and Lanyards

Zip Master on tower can perform this step while Assistants are working on inflatable targets

1. Loop the end of the lanyard around the bucket handle to prevent the trolley from rolling down the line.
2. Remove the R-clip and pin holding the Auto-Retract® brake line to the trolley.
3. Connect the end of the Auto-Retract® brake line to the hook on the tower mast.
4. Remove the 2 carabiners connecting the lanyard to the trolley (**keep a hold of the trolley**).
5. Split the trolley side plates apart and remove the trolley from the zip line.
6. Replace the R-clip and pin for the Auto-Retract® brake line back onto the trolley.
7. Place the trolleys, lanyards, and carabiners in the tool boxes for transport and storage.
8. Inspect all harnesses and store for travel (**Never store wet!**).

Improper storage and care for the trolleys, lanyards, carabiners, and harnesses will decrease the life expectancy of the equipment. Always store in a dry/clean environment!

5.3 Detach ATD Cables

Complete the following steps to detach the ATD Cables:

1. Remove the quick link on the back-up cable leg.
2. Remove the pin from the lower series of holes that are arrayed in a half circle pattern on the ATD.
3. Disconnect the steel ride cable:
 - a. One employee will pull the handle towards the tower.
 - b. Another employee will remove the pin connecting the steel ride cable to the handle.
 - c. Cable will pull towards tower as the tension is released.
4. Place pins back into the ADT.
5. Stow ATD on MZL trailer storage.

5.4 Dismantle Anchors

The dismantle method will depend on the anchor method that was employed: 2 vehicles, D.A.S.H., or water ballast.

5.4.1 Dismantle 2 Vehicle Anchors

Complete the following steps to dismantle the two vehicle anchors:

1. Retrieve the ignition keys from the tool box on the Mobile Zip Line™ trailer.
2. Unlock the vehicle doors.
3. Release the vehicle “Emergency Brake”.
4. Remove wheel chocks behind the rear tires and stow them in the zip line tool box.

The following actions will depend on which additional methods were selected to disable the vehicle:

1. Remove the steering wheel lock.
2. Remove the “Caution” sign from the steering wheel.
3. Reconnect the battery cables or disengage the battery kill switch.
4. Remove the wheel boot from the vehicle.

5.4.2 Dismantle D.A.S.H.

Complete the following steps to dismantle a D.A.S.H. anchor:

1. Remove the ATDs from each pivoting arm after releasing the steel ride cables.
2. Remove the chains from each side.
3. Remove the yellow wheel chock bar from under the vehicle.
4. Raise the stabilizer jacks on the pivoting anchor arms and secure with the U-pins.
5. Remove the 2 pivoting arms from the center mount plate by pulling out the 2 large pins.
6. Remove the center mount plate from the receiver hitch of the vehicle.
7. Store parts in the tow vehicle.

5.4.3 Dismantle Water Ballast Anchor(s)

Complete the following steps to dismantle a water ballast anchor:

1. Remove the vinyl cover from the tank and set it aside to dry.
2. Lift the tank D-rings off the corner hook and dump the water
 - a. Use a sump pump and hose if you need to control where it drains.
 - b. Similarly siphon with a hose as a measure to control drainage.
3. Remove the tank from the frame and allow it to fully dry before storing.
4. Disassemble the steel support frame and lay the pieces to the side:
 - a. Remove the 2 top tube frame pieces.
 - b. Remove the side pipe bars.
 - c. Remove the rear frame section from the base.
 - d. Remove the front frame section.
 - e. Slide the 2 base tube pieces out from under the floor.
5. Stack the Water Ballast Anchor frame on the trailer.
 - a. Use 2 employees to place the floor in the trailer and tighten the wingnuts to hold it down.
 - b. Slide the 2 base tube pieces into the rear frame and place them on the floor
 - c. Slide the 2 top tube pieces into the front frame and stack them on top.
 - d. Place the tank, cover, and side pipe bars on trailer.
 - e. Use a strap to secure all items.

5.5 Store the Cables

To store the cables, carefully roll up the steel ride cables by hand or use the cable reel.

5.6 Disconnect Guy Lines

To disconnect the guy lines, loosen the turnbuckles and disconnect the guy lines where they attach to the zip line trailer.

5.7 Unlock the Tower Mast

If the tower has been erected for several hours it may lose oil pressure to the hydraulic ram holding it up. This will cause the tower to fall several inches when the locks are removed from the tower mast. To prevent this use the remote pendent and give it a few light taps in the “up” direction before proceeding.

1. Position employee at the top of the stairs and locate the 2 yellow locks on either side of the mast.
2. Remove the locking pins and rotate the yellow locks from around the tower.

3. Rotate the locks around the bucket handles and pin in place to secure for transport.



Figure 45. Unlock Yellow Tower Locks

If you are having difficulty with the hole alignment you may need to pull the bucket handle toward you.

Failure to unlock the tower prior to attempting to lower the tower may cause permanent damage to the trailer, upper, and stairway. **This will void any and all warranties.**

5.8 Prep the Trailer for Lowering

Complete the following steps to prepare the trailer for lowering the Zip Line:

1. Remove chocks from the front and back of the wheels as pictured, on each side of the trailer and place in the tool boxes.



Figure 46. Remove the Tire Chocks

2. Remove the wheel locks between the wheels on each side and place them in the tool boxes.
3. Use the jack handles to raise each of the 4 stabilizing jacks as high as possible.
4. Pull the jack drop leg pins, slide upward, and replace pins.
5. Push in the outrigger jacks and pin tube in place.

5.9 Lower the Tower

Complete the following steps to lower the tower:

1. All employees should be off the tower and trailer.
2. **Close and secure the gate with the latch or you'll break it off when you lower the tower!**
3. **Close the tongue and secure** it with the pin and R-clip. It is critical to complete this step prior to lowering the tower. Severe trailer damage will result if you do not close the tongue/hitch assembly!



Figure 47. Tower is Ready to Lower

4. Remove the 2-Button Remote Pendant from the tool box and plug it into the receptacle.
5. Press the "DOWN" button and lower the tower until it rests on the trailer.
NOTE: There are several pinch points on the Mobile Zip Line™ - Use Extreme Caution.
6. Remove the 2-Button Remote Pendant and store them in the tool box.

5.10 Collect Tower Gear

Complete the following steps to verify that you have collected all of the tower gear:

1. Open the gate and walk up the stairs to the bucket area.
2. Remove the following items:
 - a. Steel ride cables
 - b. Guy lines
 - c. Flags
 - d. Shade canopy (if applicable)
3. Lower Employee Safety Rail for transit.
4. Reconfirm the buckets are locked in place.

5.11 Prepare for Transit

Complete the following steps to prepare for transit:

1. Carefully secure the Auto-Retract® carts with the red tie-down straps before transport.
2. Confirm that you have the following stored for transport:
 - a. ATDs
 - b. Inflatable targets
 - c. Zip line cables
 - d. Zip line gear: trolleys, lanyards, carabiners, and harnesses
 - e. Wheel chocks & tires locks
 - f. Fencing

6. TRANSPORTATION

This section of the manual contains instructions for properly transporting the Mobile Zip Line (Gen III) product. The steps for transporting the Mobile Zip Line (Gen III) are as follows:

1. Understand the transportation dimensions.
2. Connect to the towing vehicle.
3. Complete a pre-trip inspection.
4. Understand and follow the transportation rules.

6.1 Transportation Dimensions

The dimensions for the Mobile Zip Line (Gen III) product are as follows (see figure below):

- **Length:** 34'-6"
- **Height:** 11'-11"
- **Width:** 7'-6"
- **Weight:** 7000 lbs.

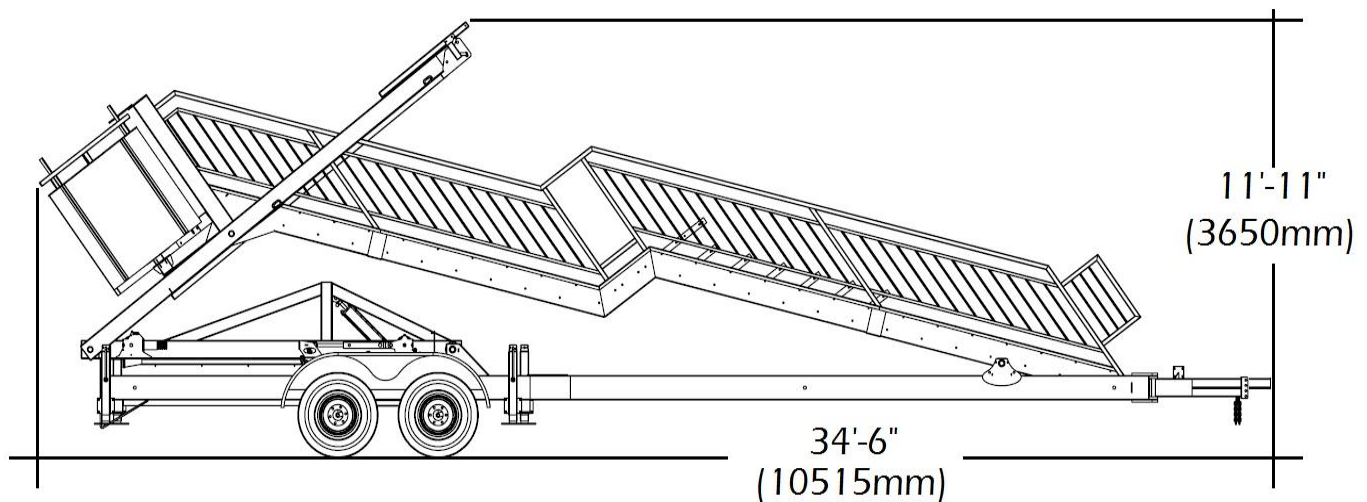

Figure 48. Transportation Dimensions

6.2 Connect to Tow Vehicle

The Mobile Zip Line™ trailer is designed to be towed level with the ground. An adjustable hitch may be required depending on the height of the tow vehicle. The ball hitch should be between 18' -22" from the ground.

- Confirm that your tow vehicle is rated for 7000 lbs. with a class 3 or greater hitch.
- Confirm that you have the appropriate **2-5/16"** ball hitch on the tow vehicle.

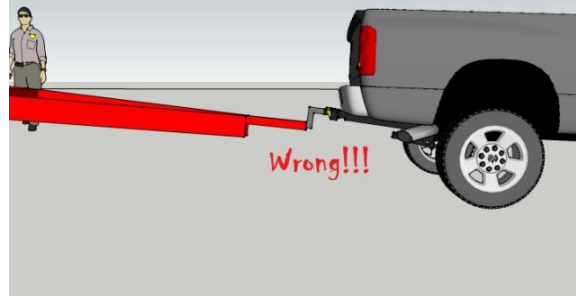

Figure 49. Improper Tow Connection

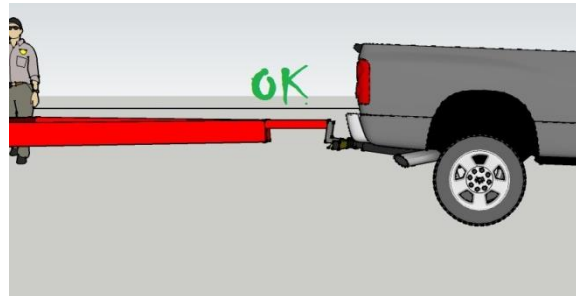

Figure 50. Proper Tow Connection

The following steps **MUST** be followed each and every time the trailer is connected to a tow vehicle:

1. Remove the pin from the trailer coupler and slide it to the open position.
2. Back the tow vehicle until the ball hitch is directly under the trailer coupler.
3. Use the jack on the trailer tongue to lower the coupler onto the ball hitch.
4. Slide the coupler into the closed position and secure it with the locking pin.
5. Connect both safety chains to the tow vehicle (cross the chains).
6. Secure the “brake-away” cable to the tow vehicle.
7. Connect the round 7-pin electrical plug from the trailer to the tow vehicle.

6.3 Pre-Trip Inspection

To perform a pre-trip inspection, complete the following tasks:

- Tires properly inflated.
- Torque lug nuts to 85ft lbs.
- Spare tire secure and properly inflated.
- In-line fuses 20-amp min.
- Hitch pin on coupler securely locked.
- Safety tie down straps snug and secure on the 2 Auto-Retracts®.
- All jacks are raised to a travel position with proper pins in place.
- Buckets are secure and in lock position.
- Adjust mirrors so you can see the trailer clearly.
- Check to ensure that your brakes work properly on both the tow vehicle and the trailer.
- Test to make sure that all lights are working properly on both the tow vehicle and the trailer.
- Walk around the trailer and vehicle, looking for any items that may be out of place.

6.4 Transportation Rules

It is your responsibility to practice safe driving while towing the Mobile Zip Line™. Observe the following rules:

1. Do not exceed 65 mph while towing.
2. Do not transport in snow, ice, heavy rain, or if winds exceed 40 mph.
3. Obey all traffic rules, laws, and speed limits.
4. No texting while towing the Mobile Zip Line™.
5. Make wide sweeping turns.
6. Allow yourself plenty of room for braking.
7. Be aware of the trailer height, width, and length.
8. Plan ahead so that you have plenty of time to get to your event/location.

7. WARRANTY

7.1 Warranties and Liabilities

The warranty set forth below represents the manufacturer's sole warranty and is in lieu of any other express or implied warranties or obligations of Spectrum Sports Intl, its distributors, resellers/retailers, or employees. This warranty is null and void if other than genuine parts are used, or if any modifications are made without the express written permission of the manufacturer. This warranty only applies to the original purchaser, and is contingent upon the owner/operator using and maintaining the product in accordance with this manual.

Limited Product Warranty

The Mobile Zip Line™ by Spectrum Sports Intl is warranted free from defect in material and workmanship for a period of 90 days from the date of purchase.

Additionally, the steel trailer and tower are warranted for 1-year on welds and structure (this does not include powder coat or any frame damage due to improper set-up or damage due to misuse).

Equipment not manufactured by Spectrum Sports Intl (harnesses, lanyards, trolleys, chocks, wheel locks, etc.) is covered to the extent of the warranty provided by the original manufacturer.

Limitation of Remedy

Spectrum Sports Intl reserves the right to determine if a product is under warranty. Spectrum Sports Intl may elect at their discretion to use fabricators, distributors, and/or service agents' local to a customer to determine the cause and/or repair of the particular part.

Spectrum Sports Intl's sole obligation under this warranty shall be to repair or replace any part or parts which, to their satisfaction, prove to be defective upon inspection. This obligation does not include labor to install replacement parts.

All claims in regards to the parts or equipment must be made within the warranty period.

To obtain repair or replacement parts, call **888-563-0163** or email **service@spectrumsports.com** for a **return authorization number**. Include the following information:

- Company Name
- Contact Name
- Office/Mobile Phone Number
- Ship-to Address
- Date of Purchase
- Product Model
- Serial Number

At your expense, please ship or deliver the product or part to:

Spectrum Sports Intl
324 W 2500 N Bldg A
North Logan, Utah 84341

Replaced or repaired items will be shipped back to you at no cost and will be shipped in the same manner as they were received (i.e. overnight, 2nd day, ground, LTL freight, etc.).

For replacement parts that must be shipped to the customer before the original part is received back by Spectrum Sports Intl, it is REQUIRED that a valid credit card be charged for the replacement part before Spectrum Sports Intl will ship. Once Spectrum Sports Intl receives the original part, and if it deems that it is covered by warranty, a credit will be issued back to the credit card.

Spectrum Sports Intl is in no way responsible for lost revenue or income while product is not in operation due to warranty or any other problems due to installation and/or operations.

Warranty is only extended to the original owner.

Wear parts are not included under this warranty.

Should it be determined that the defect is due to abuse or misuse, any and all warranty rights or responsibilities are void.

If the purchaser defaults in making payment for any parts or equipment, this warranty shall be void and shall not apply to such parts and equipment. No late payment or cure of default in payment shall extend the warranty period provided herein.

The warranty on Spectrum Sports Intl equipment remains valid only when genuine OEM Spectrum Sports Intl replacement parts are employed. Spectrum Sports Intl reserves the right to void warranty on any customer-modified parts. Furthermore, customer will indemnify and hold Spectrum Sports Intl harmless from any damage or injury caused, including damage to the reputation, name, and good will of Spectrum Sports Intl.

If anyone other than a Spectrum Sports Intl authorized service technicians perform work or modify/repair any part of the product, it will VOID any warranty claim and will indemnify Spectrum Sports Intl from any liability.

The following items are considered to be the responsibility of the Customer, and therefore, are not included under the terms of the warranty:

- Normal maintenance/routine services.
- Normal replacement of service items.
- Replacements required because of abuse, misuse, or incorrect operation of equipment by the installer or operator.
- Normal deterioration due to use and exposure.

Strict adherence to this manual and the instructions herein or provided by Spectrum Sport Intl and its service technicians is also a condition of warranty.

THIS WARRANTY IS EXPRESSLY IN LIEU OF OTHER WARRANTIES, EXPRESS OR IMPLIED, AND ANY IMPLIED WARRANTY OF MERCHANTABILITY OR FITNESS FOR A PARTICULAR PURPOSE IS HEREBY EXPRESSLY EXCLUDED.

Waiver & Release from Liability

NOTICE: BY ACCEPTING YOUR _____, YOU ARE ACKNOWLEDGING THAT YOU HAVE READ, UNDERSTOOD AND ACCEPTED THE TERMS AND CONDITIONS STATED IN THIS MANUAL. YOU

SPECTRUM SPORTS INTL

324 W 2500 N Bldg A | North Logan, UT 84341 | 888-563-0163

FURTHER ACKNOWLEDGE AND AGREE THAT YOU ARE WAIVING YOUR RIGHTS TO SUE OR BRING A COURT ACTION TO RECOVER COMPENSATION OR OBTAIN ANY OTHER REMEDY FOR ANY INJURY TO YOURSELF OR YOUR PROPERTY.

This Release, Waiver and Assumption of Risk (“Agreement”) entered into by and between the owner/operator, on behalf of his/her/its heirs, legal representatives, personal representatives, attorneys, affiliates, administrators, successors and assigns (“Releasor”) and in favor of KBG International, Inc. a Utah corporation doing business as Spectrum Sports Intl, its past, present and future officers, directors, stockholders, attorneys, agents, servants, representatives, employees, subsidiaries, affiliates, partners, insurers, predecessors and successors in interest, indemnitors, assigns and other related or affiliated entities or persons (“Releasee”), desires to operate a _____ and any other recreational activities associated therewith (the “Activities”). In consideration for Spectrum Sports Intl providing maintenance or service to my equipment or permitting me to purchase and/or otherwise operate and engage in these Activities, I have agreed to execute this Acknowledgment, Waiver & Release and further, more particularly, agree as follows:

ACKNOWLEDGEMENT: I acknowledge and am thoroughly aware that there are significant inherent risks and hazards associated with the Activities and all other outdoor recreational activities or being a spectator of these Activities. **I FULLY ACKNOWLEDGE AND UNDERSTAND THAT PARTICIPATION IN THESE ACTIVITIES CONTAINS INHERENT RISKS THAT MAY BE UNKNOWN OR UNANTICIPATED THAT MAY RESULT IN PHYSICAL OR EMOTIONAL INJURY INCLUDING BUT NOT LIMITED TO PARALYSIS, PERMANENT INJURY OR DEATH AND DAMAGE TO PROPERTY OR TO OTHER THIRD PARTIES.**

I further acknowledge that the nature and extent of the risks and hazards inherent in the Activities and my pursuit of these activities include or operating equipment associated with the Activities, but are not limited to:

1. Severe bodily injury or death resulting from the Activities and equipment utilized in connection with the Activities;
2. Severe bodily injury or death resulting from equipment failure and/or malfunction of my own or others’ equipment, including, but not limited to, failures of ropes, slings, climbing harnesses, bolts, bolt hangers, fixed anchor points;
3. Severe bodily injury or death resulting from falling climbers/participants or falling or dropped items, including, but not limited to, ropes, climbing hardware or other debris;
4. Severe bodily injury or death from improperly placed or faulty climbing protection, improperly tied knots, improperly buckled harnesses, or improper rope/cable, belay, rope/cable ascending or rope/cable descending techniques;
5. Severe bodily injury or death resulting from operator or participants own negligence or the negligence of others including other climbers, operators, participants, spectators or users;
6. Severe bodily injury or death resulting from personal physical and mental limitations, including, but not limited to, fatigue, chill and/or dizziness, personal strength, coordination, sense of balance, which may diminish reaction time and increase risks of accident and ability to follow or give directions while climbing, lifting, spotting or being a spectator;

7. Severe bodily injury or death resulting from hazardous terrain or adverse weather conditions, including wind, rain, snow, hail or sleet;
8. Severe bodily injury or death resulting from not following proper and customary personal safety procedures including procedures outlined in the owner's manual for the equipment
9. Severe bodily injury or death resulting from not having qualified personnel maintain or service the equipment and/or not properly inspecting the equipment in accordance with the owner's manual.

I acknowledge that the above list of severe bodily injuries, dangers, hazards, and risks are described by way of example only, and are not inclusive of all possible risks associated with the Activities, and that other unknown and unanticipated risks may result in bodily injury, illness or death. **I VOLUNTARILY ASSUME ALL SUCH RISKS WITH FULL KNOWLEDGE AND APPRECIATION OF THE DANGERS AND RISKS INVOLVED.**

RELEASE ASSUMPTION OF RISK AND RESPONSIBILITY: In consideration of my being allowed to participate and operate the equipment to conduct the Activities, and in recognition of the inherent risks of the Activities, I knowingly and intentionally agree on behalf of myself, my/our heirs, representatives, successors, officers, directors, stockholders, employees, executors, administrators, assigns, and anyone claiming interest through me, or on my behalf hereby **KNOWINGLY, INTENTIONALLY, AND VOLUNTARILY, RELEASE, WAIVE, DISCHARGE, HOLD HARMLESS AND AGREE NOT TO SUE** Releasees in or from any and all actions, suits, claims damages and liability (**INCLUDING ATTORNEY FEES OR COSTS**) or demands, obligations and/or causes of action of any nature whatsoever which I/we or, my heirs, representatives, successors, officers, directors, stockholders, employees, executors, customers, participants, administrators, assigns, and anyone claiming interest through me or my customers/participants may have against Releasees on account of any personal injury, property damage, death or accident of any kind arising out of or in any way connected with my operation of any equipment or anyone's participation in the Activities. I agree to indemnify and hold harmless Releasees from any and all liabilities or claims made by other individuals or entities as a result of my operation of or participation in the Activities. This release shall be effective even though said loss, damage, injury, paralysis, loss, or death results or has resulted from negligence, wrongful acts, omissions, breach of warranty or strict tort liability of Releasees (whether as the manufacturer or servicer of the equipment).

I further certify, acknowledge and agree on behalf of myself (or the company listed above) that I am physically and mentally capable of participating in these Activities;

I assume responsibility for and voluntarily assume the risks for any personal injury, death and related expenses involved with these Activities;

I assume responsibility for damage to my/our person or property or the person or property of participants in the Activities;

I agree to indemnify and hold harmless Releasees for any and all claims, as well as all fees and costs. I further agree to indemnify and hold harmless Releasees for any and all claims for products they did not manufacture, maintain or service.

I also understand that Spectrum Sports Intl is not responsible for claims or allegations regarding any product manufactured or produced by other parties or entities.

I certify that I have adequate insurance to cover any injury or damage I may cause or suffer while operating or participating, or else I agree to bear the costs of such injury or damage to myself or my customers. I further agree to name Spectrum Sports Intl as an additional insured party on my liability insurance policy with limits of not less than \$1,000,000 per occurrence and \$2,000,000 in the aggregate.

Agreement & Acknowledgement

I have fully *read* the provided Operation and Owner's Manual and *understand* how to safely set up, inspect, operate, take-down, transport, maintain, and manage crowd and staffing issues for the Mobile Zip Line™ by Spectrum Sports Intl. I agree to operate only in accordance with these instructions and follow all of the warnings and cautions set forth in the manual.

I have carefully read the Limited Product Warranty, Limitation of Remedy, and Release of Liability and fully understand its contents. **I am aware that this is a release of liability and a contract between me and Spectrum Sports Intl and its manufacturers, distributors, retailers, and employees.**

If I do not understand the contents of this manual or warranty, or if I do not willfully accept the personal liability in the operation of the Mobile Zip Line™, I will immediately notify Spectrum Sports Intl in writing. I also acknowledge that I will not operate the said products until I do so.

7.2 Conclusion

This owner/operator manual has been written to assist in the proper installation and operation of the Mobile Zip Line (Gen III). Spectrum Sports Intl has tried in its best effort to address relative issues; however, there will be additional information learned or situations that occur that we are unaware of at this time. Please, do not hesitate to call with any technical questions, issues, or concerns that may arise through the use of this product that are not listed or addressed in this manual, please keep us informed. It is the responsibility of the owner/operator of this product to contact Spectrum Sports Intl if any questions arise. As with any amusement/safety device, physical harm may occur and operators and participants must realize that this product is a physical activity and that proper care should be taken to ensure safety. Please exercise good common sense and judgment while operating the Mobile Zip Line (Gen III).



Warning!

It is the customer's sole responsibility to clarify any question or concern with Spectrum Sports Intl before use and/or operation.

APPENDICES

APPENDIX A. FORMS

COMPANY:			SHIP TO:		
CONTACT:					
PHONE:			<input type="checkbox"/> Residential?		
EMAIL:			BILL TO:		
Payment: Credit Card / PO# / Warranty / Wire / Net 30					
Shipping: Ground / 2-Day / 3-Day / Overnight / DHL					
Item Description	Price	Qty	Item Description	Price	Qty
Annual Replacement Parts Kit	\$ 1,250		Trolley	\$ 460	
Auto-Retract® Rope (2)	\$ 199		*Trolley Pin (2)	\$ 5	
Ride Cable (2)	\$ 395		Replacement Tread	\$ 80	
Guy Cable 29'	\$ 50		Tread Kick Plate (for PA & NJ)	\$ 15	
Turn Buckles	\$ 60		Stair Bolts (Set of 4)	\$ 10	
*Bent-Pull Pin 5/8" x 3" (6)	\$ 10		Lock Collar	\$ 10	
Measuring Rope	\$ 30		ZL Bucket Shock	\$ 60	
Power Unit	\$ 1,295		Rubber Grip (Set of 2)	\$ 15	
Front Jack	\$ 175		Plastic for ZL Buckets	\$ 500	
Jack Leg Pin	\$ 14		Plastic for Operator Station	\$ 350	
Rear Jack 10K lbs.	\$ 240		Gate w/ Sign	\$ 300	
ZL Extension Tube	\$ 320		Gate Hinges	\$ 30	
*Extension Tube Pin (4)	\$ 10		Gate Lock	\$ 60	
Remote (2 Btn.)	\$ 225		Inflatable	\$ 1,600	
Wheel Chock	\$ 30		Blower	\$ 250	
Wheel Lock (Set of 2)	\$ 100		Lanyard (Rider)	\$ 50	
7 Prong Trailer Plug	\$ 30		Lanyard (Operator)	\$ 15	
Remote Trlr. Plug: Aluminum	\$ 80		Red Strap	\$ 16	
1" Hitch Pin	\$ 35		Kids Harness (3' to 4')	\$ 60	
Fender Installation Sticker	\$ 40		Harness: M/L (4'-6"), XL (6'-6'8")	\$ 125	
Auto-Retract Cylinders	\$ 120		ZL Flags (Set of 4)	\$ 100	
Pulleys	\$ 22		Carabineer	\$ 24	
Bearings	\$ 3		Tool Box	\$ 400	
Pressure Gauge	\$ 30		Auto-Tensioning Device (ATD)	\$ 950	
Oil Eye	\$ 10		ATD Shock	\$ 45	
*Latch Safety Pin 1/2"x 2 1/2" (2)	\$ 10		*Bent-Pull Pin 1/2" x 2-1/2" (4)	\$ 12	
Pulley Bolt 5/8" x 12" (4)	\$ 14		Fencing Rack	\$ 500	
Pulley Bolt 5/8" x 3-1/2" (2)	\$ 4		Cable Reel	\$ 500	
Nylon Lock Nuts 5/8" (6)	\$ 2		Shade Canopy	\$ 1,500	
Pin Kit (*Items)	\$ 150		D.A.S.H.	\$ 2,500	
*3/8" Pin for Operator Safety Rail	\$ 10		Water Ballast Anchor	\$ 3,500	
Touch Up Paint - Rustoleum - Sunrise Red			Water Ballast Anchor & DASH	\$ 5,500	
Items to be replaced Annually in red			Bucket Turn Table	\$ 230	



Pulled By:	
Cable Serial Numbers:	Spool:
Rope Serial Numbers:	Spool:
Box Weight:	

Figure 51. Mobile Zip Line (Gen III)/Zip Accessories & Parts Order Form

APPENDIX B. ASTM F 1305



Designation: F 1305 – 94

Standard Guide for the Classification of Amusement Ride and Device Related Injuries and Illnesses¹

This standard is issued under the fixed designation F 1305; the number immediately following the designation indicates the year of original adoption or, in the case of revision, the year of last revision. A number in parentheses indicates the year of last reapproval. A superscript epsilon (ϵ) indicates an editorial change since the last revision or reapproval.

1. Scope

1.1 This guide provides a uniform procedure that should be used when classifying patron injury and illness data related to amusement rides and devices.

1.2 *This standard does not purport to address all of the safety concerns, if any, associated with its use. It is the responsibility of the user of this standard to establish appropriate safety and health practices and determine the applicability of regulatory limitations prior to use.*

2. Terminology

2.1 *Definitions of Terms Specific to This Standard:*

2.1.1 *illness*—personal discomfort resulting in treatment including a personal illness, food poisoning, drug abuse, toxic inhalation, insect sting, or other similar occurrence.

2.1.2 *injury*—sustained bodily harm resulting in treatment such as trauma, cuts, bruises, burns, and sprains.

2.1.3 *minor injuries/illnesses*—injuries and illnesses which may or may not require emergency first aid or significant treatment, or both, but cannot be otherwise classified as a serious injury or illness. This category includes incidents where treatment is limited to such things as the dispensation of over-the-counter medication or plastic adhesive strips², cleansing, rest, and other similar duties or assistance.

2.1.4 *serious injuries/illnesses*—a personal injury/illness that results in death, dismemberment, significant disfigurement, permanent loss of the use of a body organ, member, function, or system, a compound fracture, or other significant injury/illness that requires immediate admission and overnight hospitalization and observation by a licensed physician.

3. Significance and Use

3.1 The purpose of this guide is to provide a uniform procedure under which the amusement ride and device industry can organize data related to injuries and illnesses. This classification system may be used to formulate statistical information within the categories provided and will facilitate the analysis of

¹ This guide is under the jurisdiction of ASTM Committee F-24 on Amusement Rides and Devices and is the direct responsibility of Subcommittee F24.40 on Operations.

Current edition approved April 15, 1994. Published June 1994. Originally published as F 1305-90. Last previous edition F 1305-90.

² Band-Aid brand adhesive strips, a trademark of Johnson and Johnson Products, Inc., New Brunswick, NJ 08093, have been found suitable for this purpose.

injury and illness incidents. The classification system may assist owner/operators and manufacturers to review incidents directly related to their amusement rides and devices, and may provide information for alternatives to reduce or eliminate similar occurrences.

4. Recording Recommendations

4.1 The administration of emergency health care service and treatment should be recorded as deemed appropriate by the owner/operator of amusement rides and devices to include the documentation of all first-aid treatment, including minor injuries and illnesses, in a first-aid log. Injuries and illnesses other than minor should be reported on a firstaid incident report in accordance with 4.2.

4.2 *First-Aid Incident Report*—A first-aid incident report should be completed for injuries or illnesses that result in hospital admission or where medical treatment is given, recommended, or may be required at a future date. All injuries or illnesses reported and other than those classified as minor, can be presumed to be in this category.

4.3 *Recorded Information:*

4.3.1 Information recorded in the first-aid incident report should include but not be limited to the following, where applicable:

4.3.1.1 Date the incident occurred.

4.3.1.2 Name, address, and telephone number of the person to receive emergency health care service or treatment.

4.3.1.3 Age of the person to receive emergency health care service or treatment.

4.3.1.4 Manufacturer's name of the amusement ride or device where or on which the incident occurred.

4.3.1.5 Description of the injury or illness. Physical description of the injury or illness. Description of the events causing and related to the incident.

4.3.1.6 Description of the first-aid service or treatment administered including medications given.

4.3.1.7 Incident classification in accordance with Section 5.

4.3.1.8 Additional information deemed necessary by the owner/operator.

5. Classification of First-Aid Incidents

5.1 When recording an applicable first-aid-related incident the owner/operator of an amusement ride or device should classify the injury or illness in accordance with each of the

 **F 1305**

following categories based on the available reported or observed reliable information, or both:

5.1.1 *Amusement Ride and Device Incidents Classified in Accordance with Injury Qualification and Degree of Injury*—Injury, illness, serious injury/illness, and minor injury/illness as defined in Section 2 should be determined by the owner/operator to best describe the incident circumstances.

5.1.2 *Amusement Ride and Device Incidents Classified in Accordance with Facility Implication*:

5.1.2.1 *Facility-Related Incidents*—Injuries or illnesses that occur on facility premises shall be additionally classified as “Facility Related.”

5.1.2.2 *Not-Facility Related Incidents*—Injuries or illnesses that occur off facility premises shall be additionally classified as “Not Facility Related.”

5.1.3 *Amusement Ride and Device Incidents Classified in Accordance with Facility Location*:

5.1.3.1 *Amusement Ride and Device on Ride Incident*—Injuries or illnesses that actually occur to a person while riding during the operation of the amusement ride or device, including during the start up or shut down procedures, shall be additionally classified as an amusement ride and device “On Ride Incident.”

5.1.3.2 *Loading and Unloading Incidents*—Injuries or illnesses that actually occur to a person while he is within the area designated for loading and unloading of an amusement ride or device that was under the direct control of an amusement ride and device operator or attendant shall be additionally classified as a “Loading and Unloading Incident.”

5.1.3.3 *Queue Line Incident*—Injuries or illnesses that actually occur to a person while in a queue line for an amusement ride or device shall be additionally classified as a “Queue Line Incident.”

5.1.3.4 *Other Incidents*—Injuries or illnesses that occur to a person in a location other than as described in 5.1.3.1, 5.1.3.2, or 5.1.3.3 shall be classified as other than the preceding classifications and should be categorized in accordance with other predetermined descriptions that may be established by the owner/operator.

6. Manufacturer Notification

6.1 The owner/operator of an amusement ride or device shall notify the appropriate manufacturer(s) of an incident that resulted in a serious injury as defined in 2.1.4 within seven days of the occurrence of the incident.

The American Society for Testing and Materials takes no position respecting the validity of any patent rights asserted in connection with any item mentioned in this standard. Users of this standard are expressly advised that determination of the validity of any such patent rights, and the risk of infringement of such rights, are entirely their own responsibility.

This standard is subject to revision at any time by the responsible technical committee and must be reviewed every five years and if not revised, either reapproved or withdrawn. Your comments are invited either for revision of this standard or for additional standards and should be addressed to ASTM Headquarters. Your comments will receive careful consideration at a meeting of the responsible technical committee, which you may attend. If you feel that your comments have not received a fair hearing you should make your views known to the ASTM Committee on Standards, 100 Barr Harbor Drive, West Conshohocken, PA 19428.

This standard is copyrighted by ASTM, 100 Barr Harbor Drive, West Conshohocken, PA 19428-2959, United States. Individual reprints (single or multiple copies) of this standard may be obtained by contacting ASTM at the above address or at 610-832-9685 (phone), 610-832-9555 (fax), or service@astm.org (e-mail); or through the ASTM website (<http://www.astm.org>).

APPENDIX C. WIRING SCHEMATIC

SCHEMATIC WIRING DIAGRAM FOR TEKONSHA 2010 BREAKAWAY SWITCH

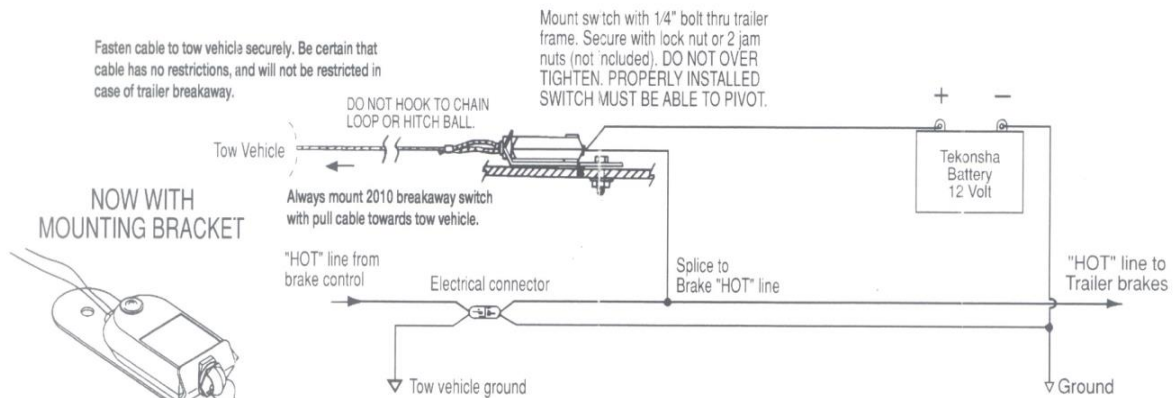

SAFETY ITEM: Solder all wire connections.

ATTENTION INSTALLER: Please give this sheet to consumer upon completion of installation.

1. Mount Tekonsha battery case securely to frame, jack post or other suitable location on trailer.
2. Bolt breakaway switch bracket to frame of trailer or battery case bracket using 1/4" bolt and lock nut or (2) 1/4" jam nuts. (Bolt and nuts not included in kit).
CAUTION: Do not overtighten bolt. Switch must be able to pivot.
3. Check and install battery.
4. Wire per schematic diagram. Properly insulate all connections.
5. Attaching to tow vehicle:
Attach cable to tow vehicle frame being certain no strain is placed on cable.
CAUTION: Do not hook cable to safety chain loop or hitch ball.
CAUTION:
 1. Switch location should be selected to insure unobstructed line of pull in event of vehicle separation.
 2. Do not let cable drag on ground.
 3. Check condition of battery prior to each trip.
 4. **WARNING: Disconnect trailer plug before testing breakaway unit. Failure to do so will result in severe damage to electronic brake control.**



















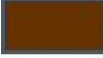

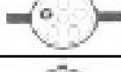

Tekonsha[®]

ENGINEERING COMPANY 537 N. CHURCH STREET, TEKONSHA, MICHIGAN 49092 Phone: (517) 767-4142

Rev. E 0698
p/n 538

Figure 52. Wiring Schematic

APPENDIX D. WIRING DIAGRAMS

TAP™	6-WAY MOLDED CABLES			7-WAY MOLDED CABLES		
	Function	Guage	Location*	Function	Guage	Location*
 yellow	Left Turn / Brake	14		Auxiliary Power	14	
 green	Right Turn / Brake	14		Tail / Marker Light	14	
 brown	Tail / Marker Light	14		Right Turn / Brake	14	
 white	Ground	14		Ground	10	
 black	Auxiliary Power	14		Battery	10	
 red	Electric Brakes	14		Left Turn & Brake	14	
 blue				Electric Brakes	12	

*Locations are given looking at the FRONT of the plug.



Figure 53. Wiring Diagram 1

Wiring Diagram for Bargman 7 and 9 Circuit, 12V Electrical Connectors

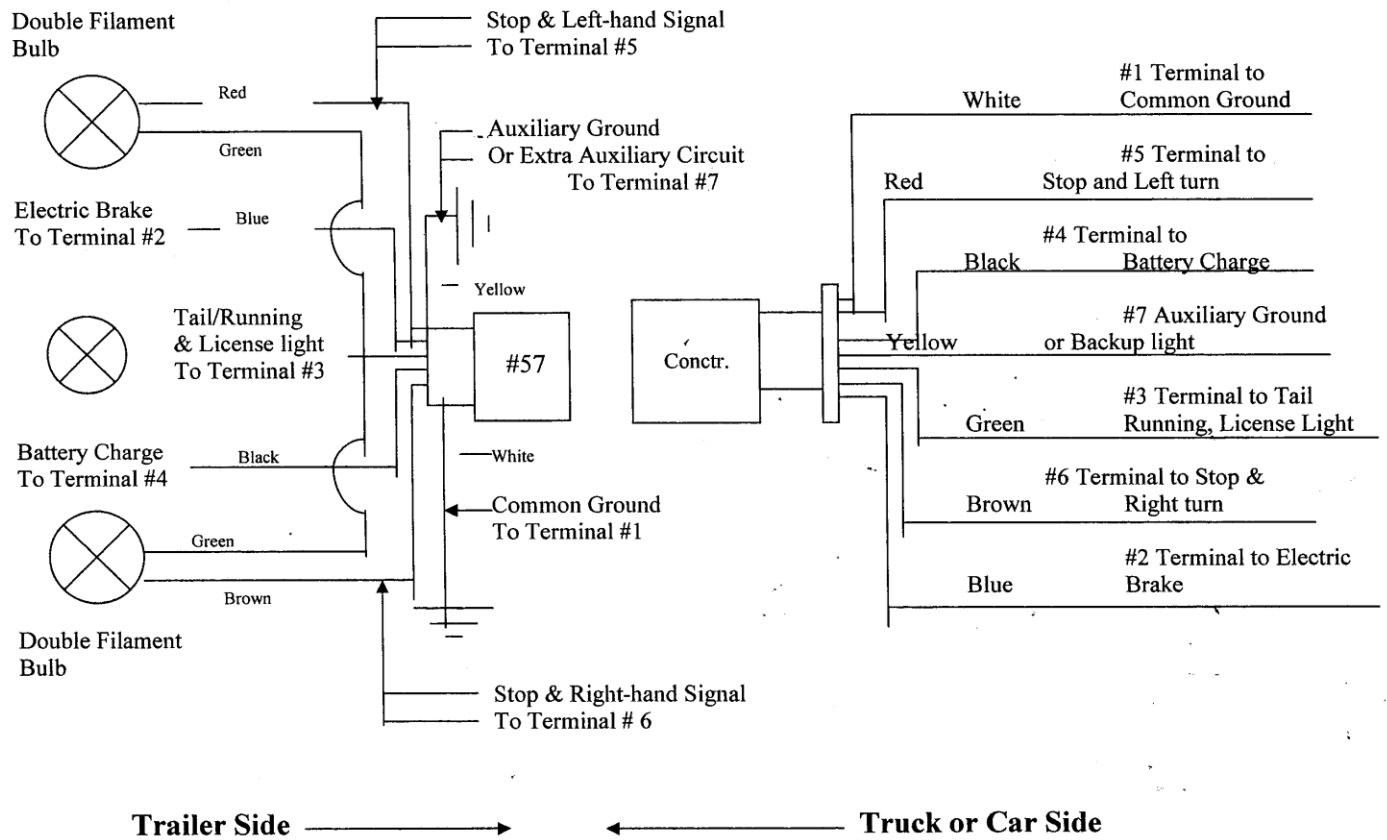

Refer to information in Dexter Axle Manual

Figure 54. Wiring Diagram 2

APPENDIX E. WHEEL LOCK INFORMATION

ULTRA-DELUXE CHOCK & LOCK TANDEM WHEEL TRAILER CHOCK INSTALLING & OPERATING INSTRUCTIONS

FUNCTION

The purpose of the Chock & Lock is to enhance trailer occupant comfort by preventing the tandem wheels from moving. When the wheels are chocked, the annoying rocking motion is essentially eliminated.

THINGS TO AVOID

Do not over tighten this wheel chock. Damage can be done to tires or Chock & Lock. This damage is not covered by the warranty.

Do not rely on this Chock & Lock as a brake. While it will assist in braking, other independent devices such as blocks or wedges should be used.

OPERATION

As the drawing shows, the Chock & Lock is to be positioned between the tandem wheels at the wheel centerline. It functions by pressing a fixed distance outward (front to back) against the two wheels, locking one wheel to the other. Because of the leverages built into the scissors mechanism and the over-center cam in the handle, modest operator effort develops tremendous force at the wheels. In normal use, the operating handle will swing through approximately a 90 degree vertical arc and stay in the "locked" (down) position by itself. The padlock hole is provided to allow for the utilization of a padlock to discourage theft of the wheel chock.

INITIAL ADJUSTMENT

Your Chock & Lock is precisely adjustable for tandem wheel spacing from approximately 1 1/2-5 1/4". The adjustment is accomplished by turning the nut on the threaded rod protruding from the top of the unit. As it is shipped, the unit is in its narrowest position and will not function. To adjust the width the first step is to pull the unit apart (wider). The threaded rod will then protrude further, exposing more threads below the nut. Turn the nut clockwise and note that this changes the operating width of the unit. Adjust until

the chock will fit closely between the two wheels with the handle in the open position (perpendicular to the "shoes"). With the unit properly adjusted, it will function every time by only moving the handle through its arc.

STIFFNESS

A new unit may be a little stiff in movement. Working it open and closed over its range a few times will normally correct this.

TIRES

The performance of the Chock & Lock is dependent on proper trailer tire pressures. Check tire pressures frequently for safety, good tire wear, and good chock performance.

ADDITIONAL ADJUSTMENT

Trailer size and geometry will influence just how tight the chock must be to work well. With experimentation, you may determine that a lighter setting, which requires less operator effort, is suitable.

There is no specific service required for your Chock & Lock. A little light lubricant on the pivots from time to time will enhance useful life.

WARRANTY

ULTRA-FAB PRODUCTS, INC. warrants that this product will be free from defects in material and workmanship for the lifetime of the original purchaser. Should a failure to conform to this warranty appear, ULTRA-FAB PRODUCTS, INC. shall, upon notification thereof, and proof of purchase, correct such non-conformity, at our option, by repair or replacement FOB factory of the defective parts.

LIMITATION OF LIABILITY

Neither party shall be liable for special, indirect, incidental or consequential damages. The remedies of the purchaser, as set forth herein, are exclusive, and the liability of ULTRA-FAB PRODUCTS, INC. shall not exceed the price of the equipment or part on which such liability is based.

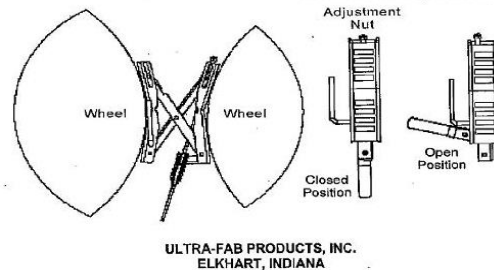

Figure 55. Wheel Lock Information